

REV.	ECN NO OR DESCRIPTION	REVISED	DATE
A	PDR NO.:A180426-2B	Vcky	2019.02.18

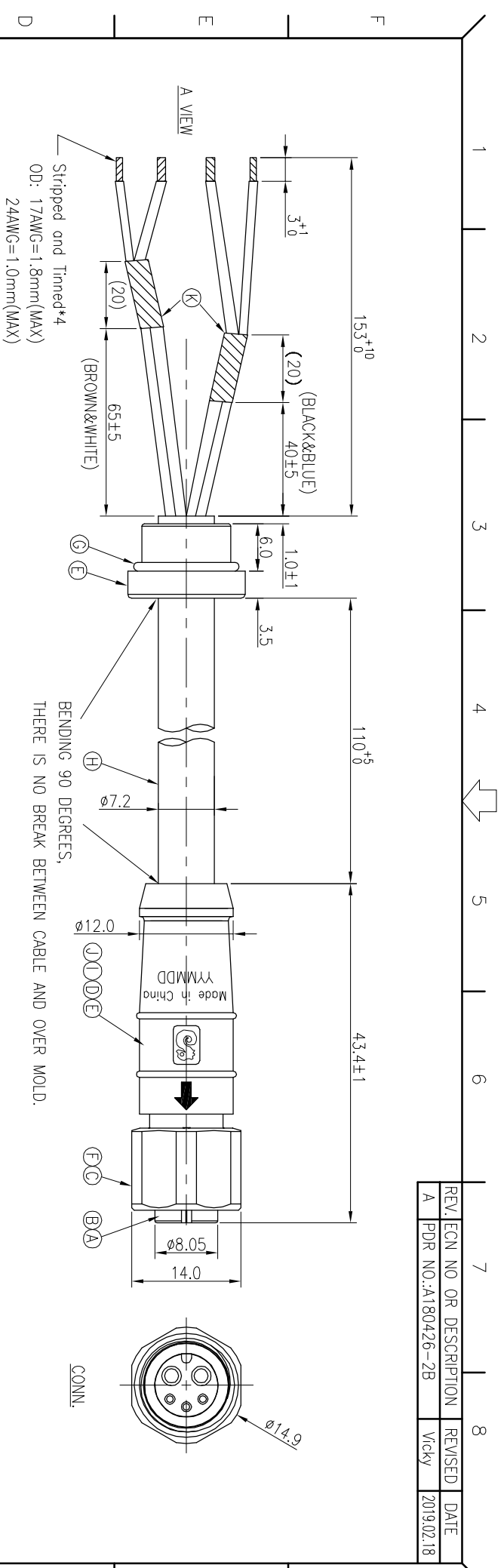

DMAT NO.	SINGATRON NO.
D30044835	2MT3010-W05944H

BLACK(24#)	5
WHITE(24#)	3
BLUE(17#)	2
BROWN(17#)	1
WIRE COLOR	CONN.
PIN OUT	

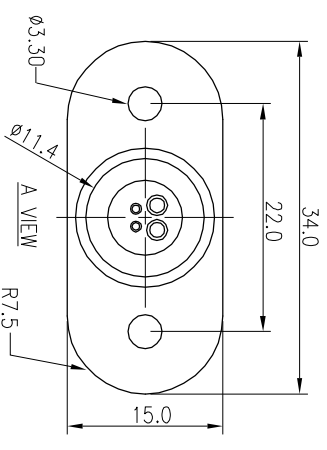
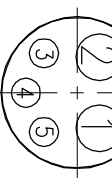

- NOTES:
1. WATERPROOF RATE: IP66/IP67
 2. ELECTRICAL CHARACTERISTICS TEMPERATURE RANGE:-40° TO +105°
 3. PULL FORCE TEST:60N min.
 4. SPECIFICATIONS:SEE "M12 SERIES SPECIFICATIONS".
 5. TO CONFORM TO ROHS REQUIREMENT AND REACH REGULATION
 6. GREEN PRODUCT IDENTIFICATION LABEL ON PACKAGING: **RoHS Pass**
 7. NON-HUMAN FACTORS CAUSE SERVICE LIFE IS 5 YEARS
 8. TORQUE FORCE: 0.8~1.0N.m
 9. SUS 316F OR SAME GRADE THAT CAN PASS 200H SALT SPRAY TEST
 - 10.LASE DATE CODE "YYMMDD" ON TOP OF OVER MOLD DATE CODE: YYMMDD DAY MONTH YEAR
- TEST CONDITION: DC300V 10Mohm 10ms
- RATING: 60V AC/DC 10A(PIN1&PIN2) 5A(PIN3&PIN5).

K	HEAT SHRINK TUBE	2	Ø5.0 300V	BLACK
J	HEAT SHRINK TUBE	2	Ø2.5 300V	BLACK
I	HEAT SHRINK TUBE	2	Ø3.0 300V	BLACK
H	CABLE	1	UL21996 17#*2C+P+ 24#*1P(UV) OD7.2 Sun Res Wet60°C Cable	BLACK (PVC JACKET)
G	O-RING	1	SILICONE	BLUE
F	O-RING	1	VITON	RED
E	OVER MOLD	2	TPEE	BLACK
D	INNER MOLD	1	TPEE	NATURAL
C	SCREW NUT	1	SEE"NOTE 9"	N/A
B	FEMALE PIN	5	Phosphor Bronze	1~3µ" GOLD PLATING OVER NICKEL PLATING
A	BODY	1	PAG6	BLACK
NO	DESCRIPTION	QTY	MATERIAL	PLATING & COLOR
UNLESS OTHERWISE SPECIFIED TOLERANCES				
TITLE FEMALE (2+3) PIN FEMALE CONN.				
SINGATRON ENTERPRISE CO., LTD. 信登企業股份有限公司				
DECIMALS: ANGLES:				
X	:±0.5	X	:±2°	
XX	:±0.3	XX	:±1°	
XXX	:±0.2			
CUSTOMER COPY				