

REV. ECN NO OR DESCRIPTION	REVISED	DATE
A PDR NO.:A190716-1B	Vcky	2019.10.23

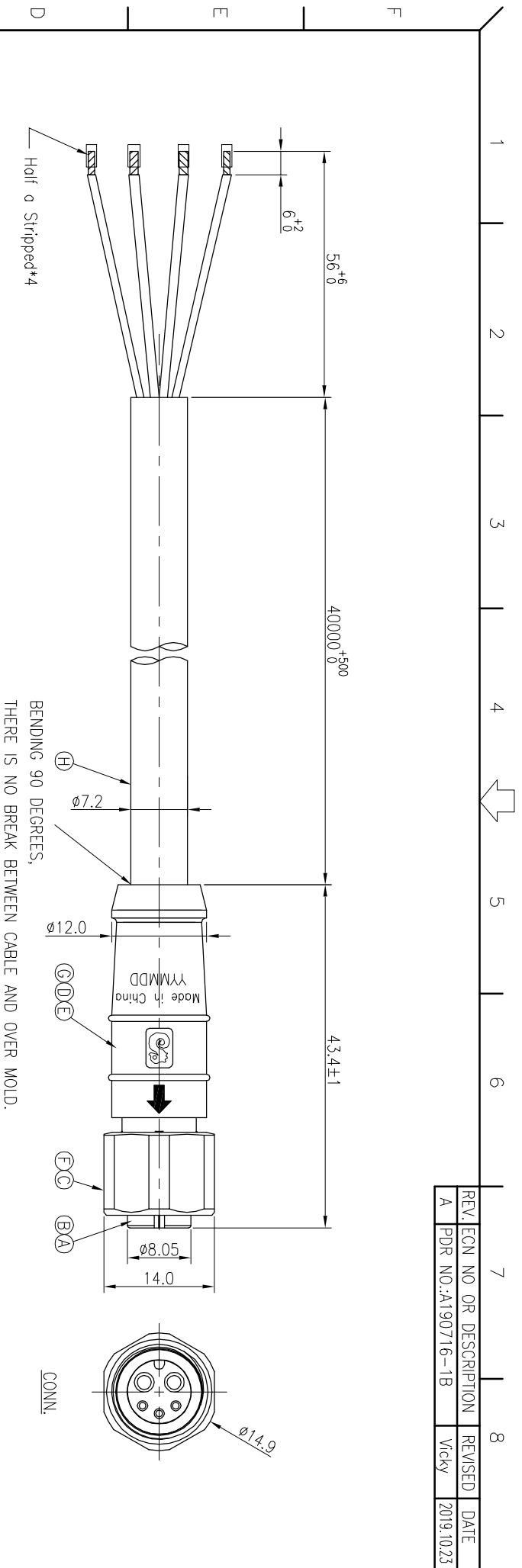

BLACK(24#)	5	
WHITE(24#)	3	
BLUE(17#)	2	
BROWN(17#)	1	
WIRE COLOR	CONN.	
PIN OUT		

- NOTES:
1. WATERPROOF RATE: IP67
  2. ELECTRICAL CHARACTERISTICS  
TEMPERATURE RANGE:-40° TO +105°  
RATING: 60V AC/DC 10A(PIN1&PIN2) 5A(PIN3&PIN5).  
TEST CONDITION: DC300V 10Mohm 10ms
  3. SPECIFICATIONS:SEE "M12 SERIES SPECIFICATIONS".
  4. TO CONFORM TO ROHS REQUIREMENT AND REACH REGULATION
  5. GREEN PRODUCT IDENTIFICATION LABEL ON PACKAGING: **RoHS Pass**
  6. NON-HUMAN FACTORS CAUSE SERVICE LIFE IS 5 YEARS
  7. TORQUE FORCE: 0.8~1.0N.m
  8. SUS 316F OR SAME GRADE THAT CAN PASS 200H SALT SPRAY TEST
  9. LAST DATE CODE "YYMMDD" ON TOP OF OVER MOLD
- DATE CODE: YYMMDD
- DAY MONTH YEAR

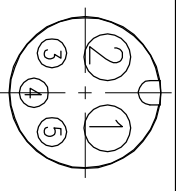

H	CABLE	1	JL21996 17#*2C+P+ 24#*1P(UV) OD7.2 Sun Res Wet60°C Cable	BLACK (PVC JACKET)
G	HEAT SHRINK TUBE	2	OD:2.4mm 含膠	BLACK
F	O-RING	1	VITON	RED
E	OVER MOLD	1	TPEE	BLACK
D	INNER MOLD	1	TPEE	NATURAL
C	SCREW NUT	1	SEE"NOTE 9"	N/A
B	FEMALE PIN	5	Phosphor Bronze	1~3u" GOLD PLATING OVER NICKEL PLATING
A	BODY	1	PA66	BLACK
NO	DESCRIPTION	QTY	MATERIAL	PLATING & COLOR

UNLESS OTHERWISE SPECIFIED TOLERANCES		信晉企業股份有限公司 Singatron Enterprise Co., Ltd.	
DECIMALS:	ANGLES:	TITLE	FEMALE (2+3) PIN FEMALE CONN.
X :±0.5	X :±2°	DMN	Vcky
XX :±0.3	XX :±1°	CHKD	Cary
XXX :±0.2		APVD	William
		PART NO.	2MT3010-W05857H
		SCALE	2:1
		UNIT:	mm
		SIZE:	A3
		SHEET:	1 OF 1
		REV:	A
CUSTOMER COPY			