

REV	ECN NO	OR DESCRIPTION	REVISED	DATE
A	PDR NO.:A220126-2B	LEI		2022.05.09

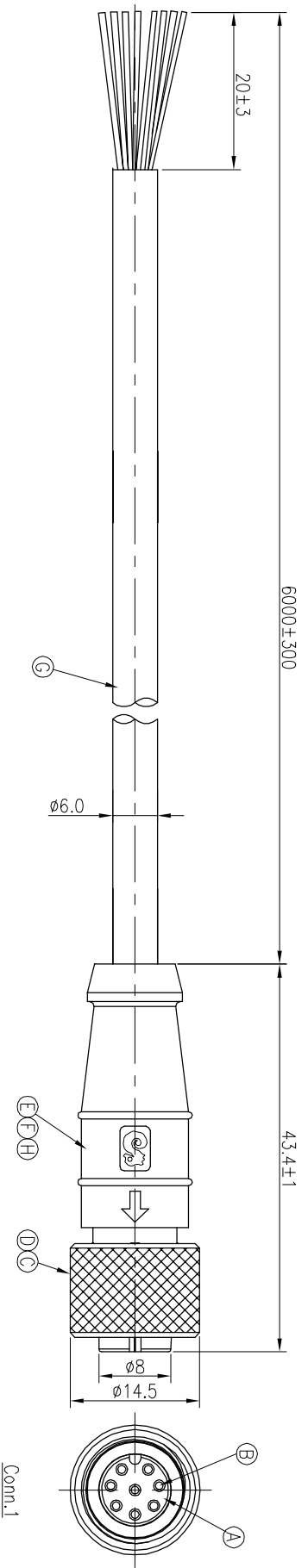

1	ORANGE/WHITE		
2	ORANGE		TWIST
3	GREEN/WHITE		
4	BLUE		TWIST
5	BLUE/WHITE		TWIST
6	GREEN		
7	BROWN/WHITE		TWIST
8	BROWN		
CONN. WIRE COLOR			
PIN DEFINITION			
CONN.			

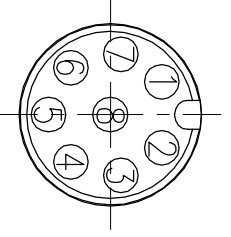

Pin Assignments
Front View

- NOTES:
1. WATERPROOF RATE: IP67
 2. CURRENT RATING: 2A/60V DC/AC
 3. SPECIFICATIONS:SEE "M12 SERIES SPECIFICATIONS".
 4. TO CONFORM TO SINGATRON HAZARDOUS SUBSTANCE FREE SPEC.
 5. GREEN PRODUCT IDENTIFICATION LABEL ON PACKAGING:

H	HEAT SHRINK TUBE	7	300V 125°	BLACK
G	CABLE (电缆)	1	CAT5E FTP 24#*4P+ MY+D+A/M	BLACK(PVC JACKET)
F	INNER MOLD	1	TPU	BLACK
E	OVER MOLD	1	TPU	BLACK
D	O-RING	1	VITON	RED
C	SCREW NUT	1	BRASS	NICKEL PLATING 100u"
B	FEMALE PIN	8	Phosphor Bronze Alloy	1~3u" GOLD PLATED OVER NICKEL PLATING
A	BODY	1	TPU	BLACK
NO	DESCRIPTION	QTY	MATERIAL	PLATING & COLOR

UNLESS OTHERWISE SPECIFIED TOLERANCES

DECIMALS:	ANGLES:
X :±0.5	X :±2°
X.X :±0.3	X.X :±1°
X.XX :±0.2	

Suzhou Singatron Auto Electronics CO.,LTD.
苏州信泰汽车电子有限公司

TITLE M12 SERIES 180° BRN FEMALE CONN.

DWN LEI PART NO.2MT3010-W08274H

CHKD Jun SCALE 2:1 UNIT: mm

APVD Steve SIZE: A3 SHEET:1 OF 1 REV: A

CUSTOMER COPY