

REV.	ECN NO OR DESCRIPTION	REVISED	DATE
A	PDR NO.:S140822-6F	JF	2015.01.10

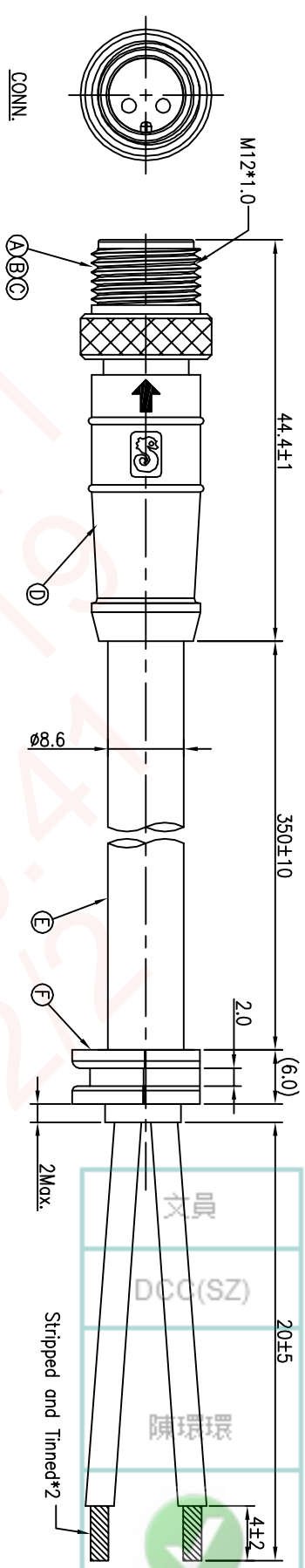

WATERPROOF RATE: IP67

CONN.

(A)(B)(C)

(D)

Ø8.6

(E)

(F)

(6.0)

2Max.

Stripped and Tinned*2

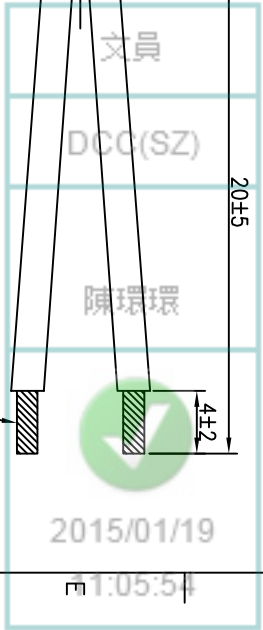

2	BLUE
1	BROWN
CONN.	WIRE COLOR
PIN OUT	
CONN.	

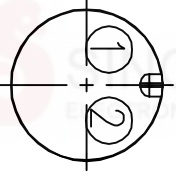

Pin Assignments
Front View

NOTES:

1. WATERPROOF RATE: IP67
2. CURRENT RATING: 10A
3. SPECIFICATIONS:SEE "M12 SERIES SPECIFICATIONS".
4. TO CONFORM TO THE SINGATRON HAZARDOUS SUBSTANCE FREE SPEC.
5. GREEN PRODUCT IDENTIFICATION LABEL ON PACKAGING:

F	SR	1	HYTREL	BLACK
E	CABLE	1	CCC 245 IEC 57(YZW) 2*1.5mm ²	BLACK(RUBBER JACKET)
D	OVER MOLD	1	TPU	BLACK
C	SCREW NUT	1	BRASS	NATURAL
B	MALE PIN	2	BRASS	1~3.1" GOLD PLATING OVER NICKEL PLATING
A	BODY	1	TPU	BLACK
NO	DESCRIPTION	QTY	MATERIAL	PLATING & COLOR
UNLESS OTHERWISE SPECIFIED TOLERANCES				
TITLE M12 SERIES 180 2PIN MALE CONN.				
SINGATRON ENTERPRISE CO., LTD. 信晉企業股份有限公司				
DECIMALS: ANGLES:				
X	:±0.5	X	:±2°	
X.X	:±0.3	X.X	:±1°	
X.XX	:±0.2			
DWN JF PART NO.2MT3012-W02304H				
CHKD Harlen SCALE 2:1 UNIT: mm				
APVD Steve SIZE: A3 SHEET:1 OF 1 REV: A				
CUSTOMER COPY				