

REV.	ECN NO.	OR DESCRIPTION	REVISED	DATE
A	PDR NO.:	S1211108-12B	James	2013.04.18
B	ECN NO.:	S130827	James	2013.08.12
C	ECN NO.:	S130908	Shawn	2013.09.29

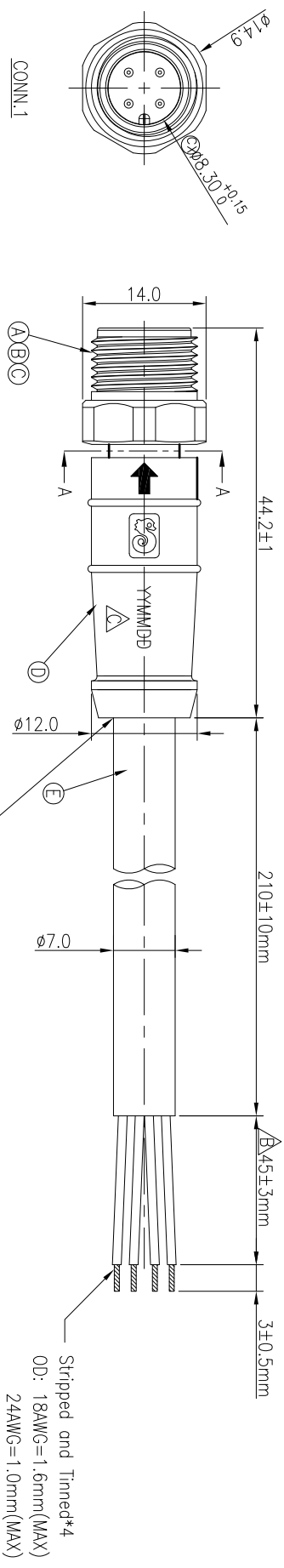

BENDING 90 DEGREES,
THERE IS NO BREAK BETWEEN CABLE AND OVER MOLD.

CUSTOMER P/N	SINGATRON P/N
MHCAH120080200	2MT3012-W04327H

SECTION B-B

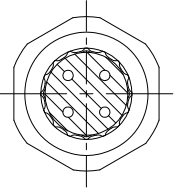

NOTES:

1. WATERPROOF RATE: IP66/IP67
2. ELECTRICAL CHARACTERISTICS
TEMPERATURE RANGE: -40° TO +80°
RATING: 60V AC/DC 6.2A
3. TEST CONDITION: DC300V 10Mohm 10ms
4. TO CONFORM TO ROHS REQUIREMENT AND REACH REGULATION
5. GREEN PRODUCT IDENTIFICATION LABEL ON PACKAGING: **GREEN PASS**
6. NON-HUMAN FACTORS CASE SERVICE LIFE IS 5 YEARS
7. TORQUE FORCE: 0.8~1.0N.m
8. SUS 316F OR SAME GRADE THAT CAN PASS 200H SALT SPRAY TEST
9. LASE DATE CODE "YYMMDD" ON TOP OF OVER MOLD

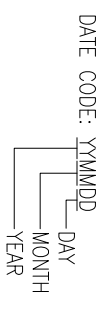

4	BLACK
3	BLUE
2	WHITE
1	BROWN
CONN.1	
WIRE COLOR	
PIN OUT	
CONN.1	

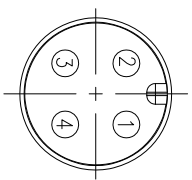

Pin Assignments
Front View

NO	DESCRIPTION	QTY	MATERIAL	PLATING & COLOR
E	CABLE	1	UL20549(-40°~+80°) 18#*2C+24#*1P UV RESISTANT OD=7.0	BLACK (PU JACKET)
D	OVER MOLD	1	TPU	BLACK
C	MALE SCREW NUT	1	SUS 316F	NATURAL
B	MALE PIN	4	BRASS	6u" GOLD PLATING OVER NICKEL PLATING
A	BODY	1	TPU	BLACK

UNLESS OTHERWISE SPECIFIED TOLERANCES

DECIMALS:	ANGLES:
X :±0.5	X :±2°
X.X :±0.3	X.X :±1°
X.XX :±0.2	

TITLE: M12 SERIES 180° 4PIN MALE CONN.
SINGATRON Enterprise Co., Ltd.
信登企業股份有限公司

DRAWN: Shawn
CHECKED: Harlen
APPROVED: Quon

PART NO. 2MT3012-W04327H
SCALE 2:1
SIZE: A3
SHEET: 1 OF 1
REV: C

CUSTOMER COPY