

REV.	ECN NO.	OR DESCRIPTION	REVISED	DATE
A	PDR NO.:	S130729-5A	Shown	2013.09.30
B	ECN NO.:	S150546-R	Lin	2015.05.22

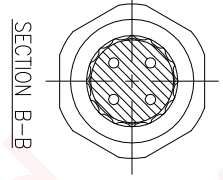

CUSTOMER P/N	SINGATRON P/N
TU.AC.0200501	ZMT3012-W04335H

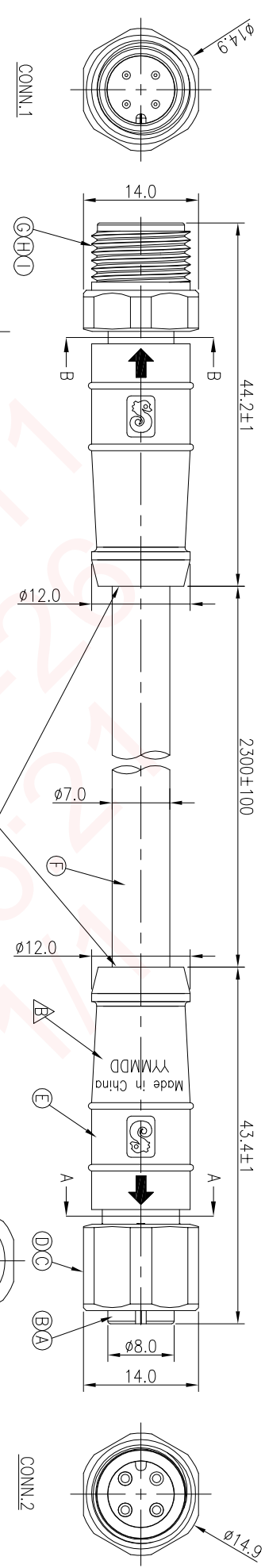
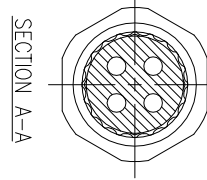

4	BLACK	4
3	BLUE	3
2	WHITE	2
1	BROWN	1
CONN.1 WIRE COLOR		CONN.2
PIN OUT		
CONN.1		CONN.2

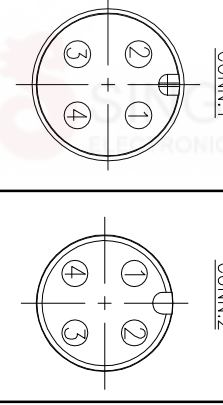

NOTES:

1. WATERPROOF RATE: IP66/IP67
2. ELECTRICAL CHARACTERISTICS
3. TEMPERATURE RANGE: -40° TO +80°
4. RATING: 60V AC/DC 6.2A
5. TEST CONDITION: DC300V 10Mohm 10ms
6. SPECIFICATIONS: SEE "M12 SERIES SPECIFICATIONS".
7. TO CONFORM TO ROHS REQUIREMENT AND REACH REGULATION
8. GREEN PRODUCT IDENTIFICATION LABEL ON PACKAGING: **GR PASS**
9. NON-HUMAN FACTORS CASE SERVICE LIFE IS 5 YEARS
10. TORQUE FORCE: 0.8~1.0N.m
11. SUS 316F OR SAME GRADE THAT CAN PASS 200H SALT SPRAY TEST
12. LASE DATE CODE "YYMMDD" ON TOP OF OVER MOLD
13. DATE CODE: YYMMDD

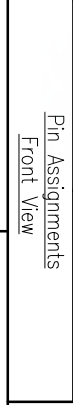

DATE CODE: YYMMDD  
DAY MONTH YEAR

ITEM	DESCRIPTION	QTY	MATERIAL	PLATING & COLOR
I	MALE SCREW NUT	1	SEE NOTE 8"	N/A
H	MALE PIN	4	BRASS	6u" GOLD PLATING OVER NICKEL PLATING
G	BODY	1	TPU	BLACK
F	CABLE	1	UL20549(-40°~+80°) 18#*2C+24#*1P UV RESISTANT OD=7.0	BLACK (PU JACKET)
E	OVER MOLD	2	TPU	BLACK
D	O-RING	1	VITON	RED
C	FEMALE SCREW NUT	1	SEE NOTE 8"	N/A
B	FEMALE PIN	4	Phosphor Bronze	6u" GOLD PLATING OVER NICKEL PLATING
A	BODY	1	TPU	BLACK

Singatron Enterprise Co., Ltd.  
信譽企業股份有限公司

TITLE	M12 SERIES 180° 4PIN FEMALE CONN. TO MALE CONN.
DWN	Lin
CHKD	Horten
APVD	Steve
PART NO.	ZMT3012-W04335H
SCALE	2:1
UNIT	mm
SHEET	1 OF 1
REV.	B