

REV.	ECN NO	OR DESCRIPTION	REVISED	DATE
A	PDR NO.:S131024-4A	Shown	2014.05.06	

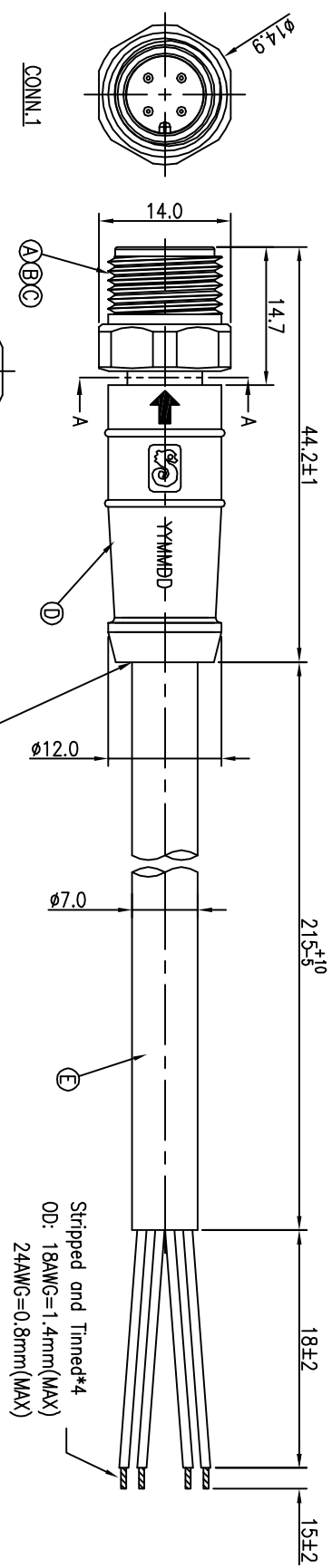

BENDING 90 DEGREES,
THERE IS NO BREAK BETWEEN CABLE AND OVER MOLD.

CUSTOMER P/N	SINGATRON P/N
MHCAH130560100	ZMT3012-W04346H

SECTION B-B

4	BLACK
3	BLUE
2	WHITE
1	BROWN
CONN.1	WIRE COLOR

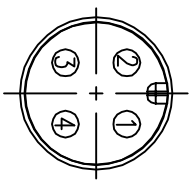

- NOTES:
1. WATERPROOF RATE: IP66/IP67
 2. ELECTRICAL CHARACTERISTICS TEMPERATURE RANGE:-40° TO +80°
RATING: 60V AC/DC 6.2A
TEST CONDITION: DC300V 10Mohm 10ms
 3. SPECIFICATIONS:SEE "M12 SERIES SPECIFICATIONS".
 4. TO CONFORM TO ROHS REQUIREMENT AND REACH REGULATION
 5. GREEN PRODUCT IDENTIFICATION LABEL ON PACKAGING:
 6. NON-HUMAN FACTORS CASE SERVICE LIFE IS 5 YEARS
 7. TORQUE FORCE: 0.8~1.0N.m
 8. SUS 316F OR SAME GRADE THAT CAN PASS 200H SALT SPRAY TEST
 9. LASE DATE CODE "YMMMD" ON TOP OF OVER MOLD
- DATE CODE: YMMMD
 DAY MONTH YEAR

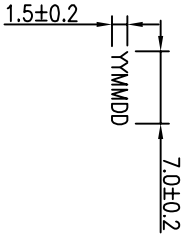

NO	DESCRIPTION	QTY	MATERIAL	PLATING & COLOR
E	CABLE	1	UL20549(-40°~+80°) 18#*2C+24#*1P UV RESISTANT OD=φ7.0	BLACK (PU JACKET)
D	OVER MOLD	1	TPU	BLACK
C	MALE SCREW NUT	1	SEE"NOTE 8"	NATURAL
B	MALE PIN	4	BRASS	6u" GOLD PLATING OVER NICKEL PLATING
A	BODY	1	TPU	BLACK

UNLESS OTHERWISE SPECIFIED TOLERANCES

DECIMALS: ANGLES:

X	:±0.5	X	:±2°
X.X	:±0.3	X.X	:±1'
X.XX	:±0.2		

DWN	Shown	PART NO.2MT3012-W04346H	UNIT: mm
CHKD	Horlen	SCALE 2:1	
APVD	Quan	SIZE: A3	SHEET:1 OF 1 REV: A

CUSTOMER COPY