

REV	ECN NO OR DESCRIPTION	REVISED	DATE
A	PDR NO.:S150114-7F	JF	2017.01.20

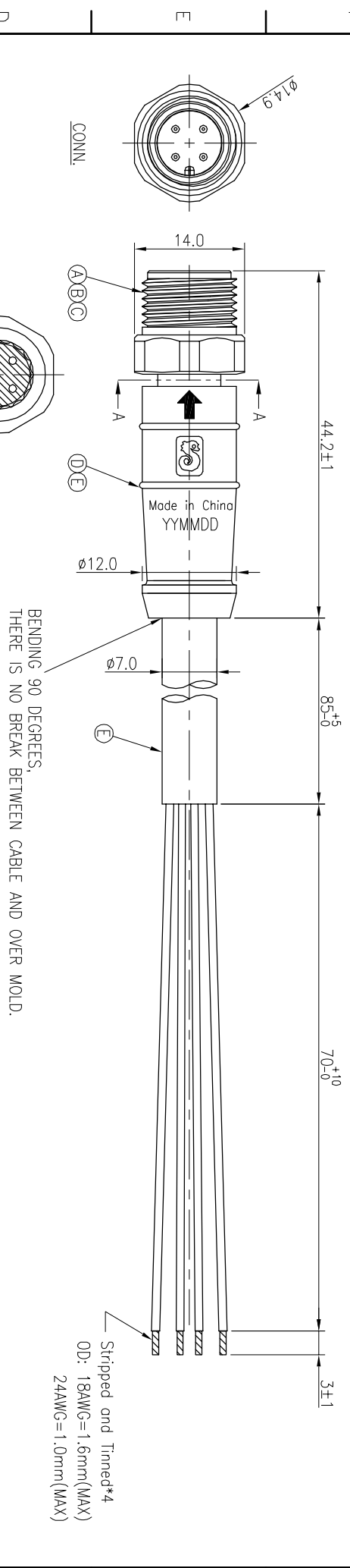

CUSTOMER P/N	SINGATRON P/N
MHCAH140020100	ZMT3012-W04383H

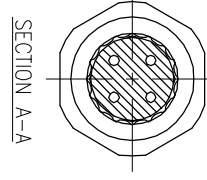

CONN.	WIRE COLOR	PIN OUT
4	BLACK(24#)	
3	BLUE(18#)	
2	WHITE(24#)	
1	BROWN(18#)	

PIN OUT

CONN.



- NOTES:
1. WATERPROOF RATE: IP66/IP67
 2. ELECTRICAL CHARACTERISTICS
TEMPERATURE RANGE:-40° TO +80°
RATING: 60V AC/DC 6.2A
TEST CONDITION: DC300V 100ohm 10ms
 3. SPECIFICATIONS:SEE "M12 SERIES SPECIFICATIONS".
 4. TO CONFORM TO ROHS REQUIREMENT AND REACH REGULATION
 5. GREEN PRODUCT IDENTIFICATION LABEL ON PACKAGING
 6. NON-HUMAN FACTORS CASE SERVICE LIFE IS 5 YEARS
 7. TORQUE FORCE: 0.8~1.0N.m
 8. SUS 316F OR SAME GRADE THAT CAN PASS 200H SALT SPRAY TEST
 9. LASE DATE CODE "YMMDD" ON TOP OF OVER MOLD
- DATE CODE: YMMDD
- DAY
MONTH
YEAR

E	CABLE	1	UL20549(-40°~+80°) 18#*2C+24#*1P UV RESISTANT OD7.0	BLACK (PU JACKET)
D	OVER MOLD	1	TPU	BLACK
C	SCREW NUT	1	SEE"NOTE 8"	N/A
B	MALE PIN	4	BRASS	6.0" GOLD PLATING OVER NICKEL PLATING
A	BODY	1	TPU	BLACK
NO	DESCRIPTION	QTY	MATERIAL	PLATING & COLOR

UNLESS OTHERWISE SPECIFIED TOLERANCES

DECIMALS: ANGLES:

X :±0.5 X :±2°
X.X :±0.3 X.X :±1°
X.XX :±0.2

Singatron Enterprise Co., Ltd.
信晉企業股份有限公司

M12 SERIES 180° 4PIN MALE CONN.

TITLE

DWN JF PART NO.ZMT3012-W04383H

CHKD Yang SCALE 2:1 UNIT: mm

APVD Horien SIZE: A3 SHEET:1 OF 1 REV: A

CUSTOMER COPY