

REV	ECN NO	OR DESCRIPTION	REVISED	DATE
A	PDR NO.:S150319-6A	JF		2015.07.10

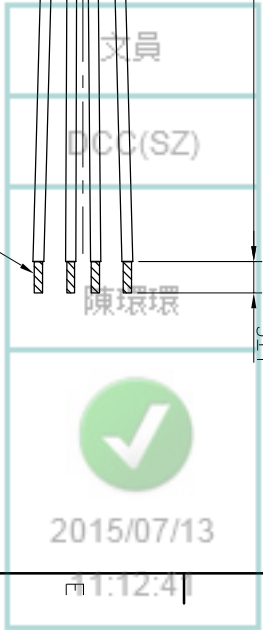

Striped and Tinned*4
 OD: 18AWG=1.6mm(MAX)
 24AWG=1.0mm(MAX)

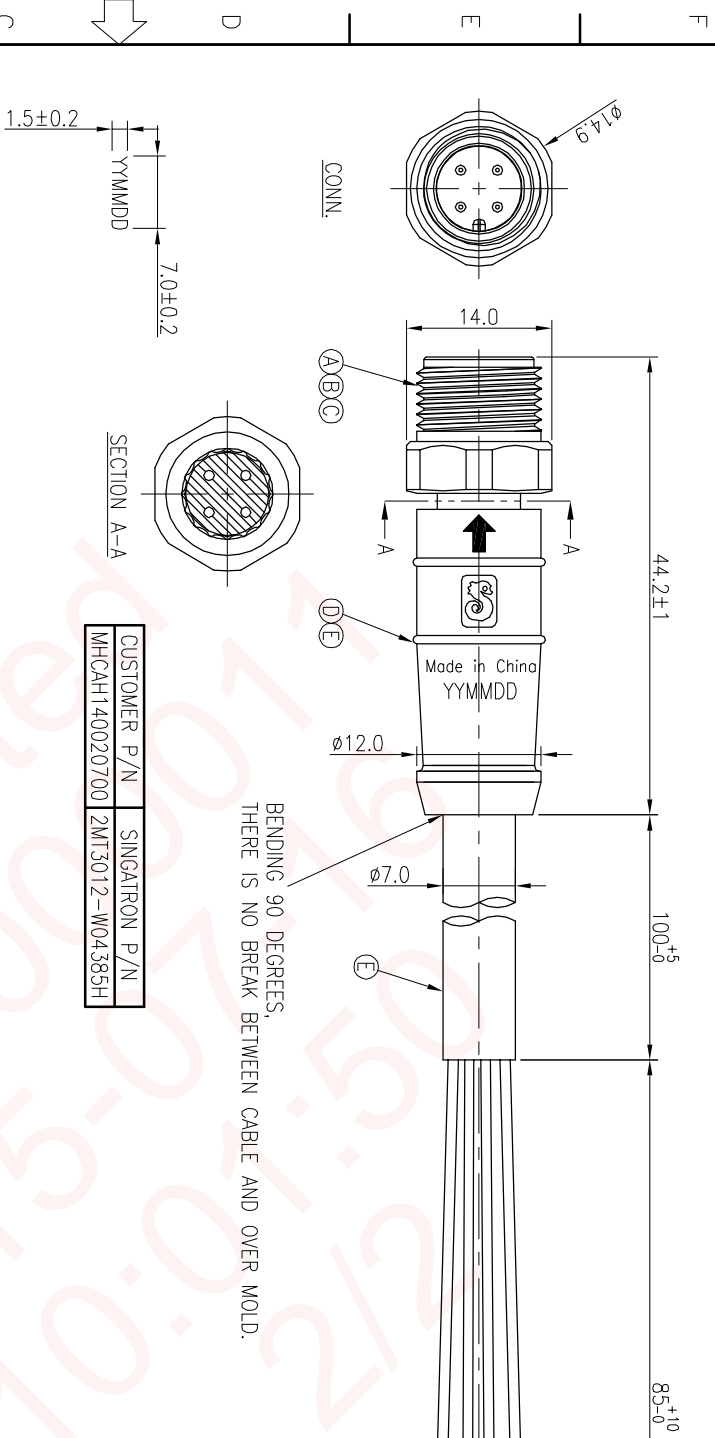

CUSTOMER P/N	SINGATRON P/N
MHCAH140020700	ZMT3012-W04385H

4	BLACK(24#)
3	BLUE(18#)
2	WHITE(24#)
1	BROWN(18#)

CONN.	WIRE COLOR
CONN.	PIN OUT

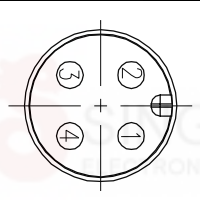

Pin Assignments
Front View

- NOTES:
1. WATERPROOF RATE: IP66/IP67
 2. ELECTRICAL CHARACTERISTICS
TEMPERATURE RANGE:-40° TO +80°
RATING: 60V AC/DC 6.2A
 3. SPECIFICATIONS:SEE "M12 SERIES SPECIFICATIONS".
TEST CONDITION: DC300V 100ohm 10ms
 4. TO CONFORM TO ROHS REQUIREMENT AND REACH REGULATION
 5. GREEN PRODUCT IDENTIFICATION LABEL ON PACKAGING: **RoHS**
 6. NON-HUMAN FACTORS CASE SERVICE LIFE IS 5 YEARS
 7. TORQUE FORCE: 0.8~1.0N.m
 8. SUS 316F OR SAME GRADE THAT CAN PASS 200H SALT SPRAY TEST
 9. LASE DATE CODE "YMMDD" ON TOP OF OVER MOLD
- DATE CODE: YMMDD
- DAY MONTH YEAR

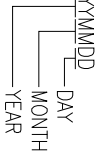

E	CABLE	1	UL20549(-40°~+80°) 18#*2C+24#*1P UV RESISTANT OD7.0	BLACK (PU JACKET)
D	OVER MOLD	1	TPU	BLACK
C	SCREW NUT	1	SEE"NOTE 8"	N/A
B	MALE PIN	4	BRASS	6.0" GOLD PLATING OVER NICKEL PLATING
A	BODY	1	TPU	BLACK

UNLESS OTHERWISE SPECIFIED TOLERANCES

DECIMALS:	ANGLES:
X :±0.5	X :±2°
X.X :±0.3	X.X :±1°
X.XX :±0.2	

Singatron Enterprise Co., Ltd.
信晉企業股份有限公司

M12 SERIES 180° 4PIN MALE CONN.

TITLE	M12 SERIES 180° 4PIN MALE CONN.
DWN	JF
CHKD	Yang
APVD	Harlen

PART NO. ZMT3012-W04385H
 SCALE 2:1 UNIT: mm
 SIZE: A3 SHEET: 1 OF 1 REV: A

CUSTOMER COPY