

REV.	ECN NO	OR DESCRIPTION	REVISED	DATE
A	PDR NO.:S151230-10B		Vicky	2015.09.08

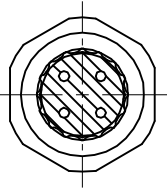

CUSTOMER P/N	SINGATRON P/N
MHCAH90140430	ZMT3012-W04386H

4	BLACK
3	BLUE
2	WHITE
1	BROWN
CONN.1	WIRE COLOR

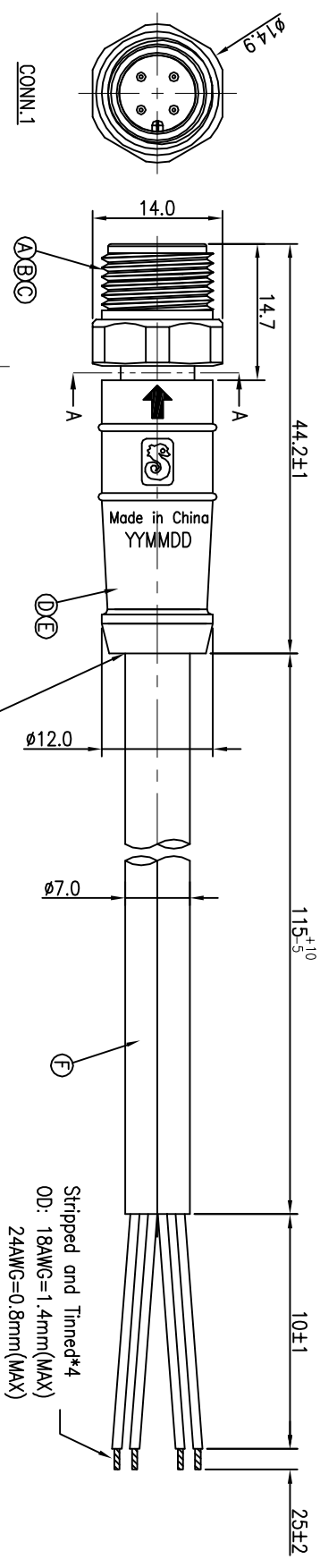
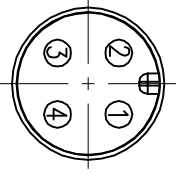

- NOTES:
1. WATERPROOF RATE: IP66/IP67
 2. ELECTRICAL CHARACTERISTICS TEMPERATURE RANGE: -40° TO +80°
RATING: 60V AC/DC 6.2A
TEST CONDITION: DC300V 10Mohm 10ms
 3. SPECIFICATIONS: SEE "M12 SERIES SPECIFICATIONS".
 4. TO CONFORM TO ROHS REQUIREMENT AND REACH REGULATION
 5. GREEN PRODUCT IDENTIFICATION LABEL ON PACKAGING:
 6. NON-HUMAN FACTORS CASE SERVICE LIFE IS 5 YEARS
 7. TORQUE FORCE: 0.8~1.0N.m
 8. SUS 316F OR SAME GRADE THAT CAN PASS 200H SALT SPRAY TEST
 9. LASE DATE CODE "YYMMDD" ON TOP OF OVER MOLD
- DATE CODE: YYMMDD
- DAY
MONTH
YEAR

F	CABLE	1	UL20549(-40°~+80°) 18#*2C+24#*1P UV RESISTANT OD=Ø7.0	BLACK (PU JACKET)
E	OVER MOLD	1	TPU	BLACK
D	INNER MOLD	1	TPU	NATURAL
C	MALE SCREW NUT	1	SEE"NOTE 8"	NATURAL
B	MALE PIN	4	BRASS	6u" GOLD PLATING OVER NICKEL PLATING
A	BODY	1	TPU	BLACK

UNLESS OTHERWISE SPECIFIED TOLERANCES		TITLE	
DECIMALS:	ANGLES:	M12 SERIES 180° 4PIN MALE CONN.	
X :±0.5	X :±2°	Singatron Enterprise Co., Ltd.	
X.X :±0.3	X.X :±1°	信登企業股份有限公司	
X.XX :±0.2		PART NO. ZMT3012-W04386H	
		SCALE 2:1 UNIT: mm	
		SIZE: A3 SHEET: 1 OF 1 REV: A	

Pin Assignments
Front View

CUSTOMER COPY