

REV.	ECN NO.	OR DESCRIPTION	REVISED	DATE
A	PDR NO: S130812-8A		Harlan	2015.8.11

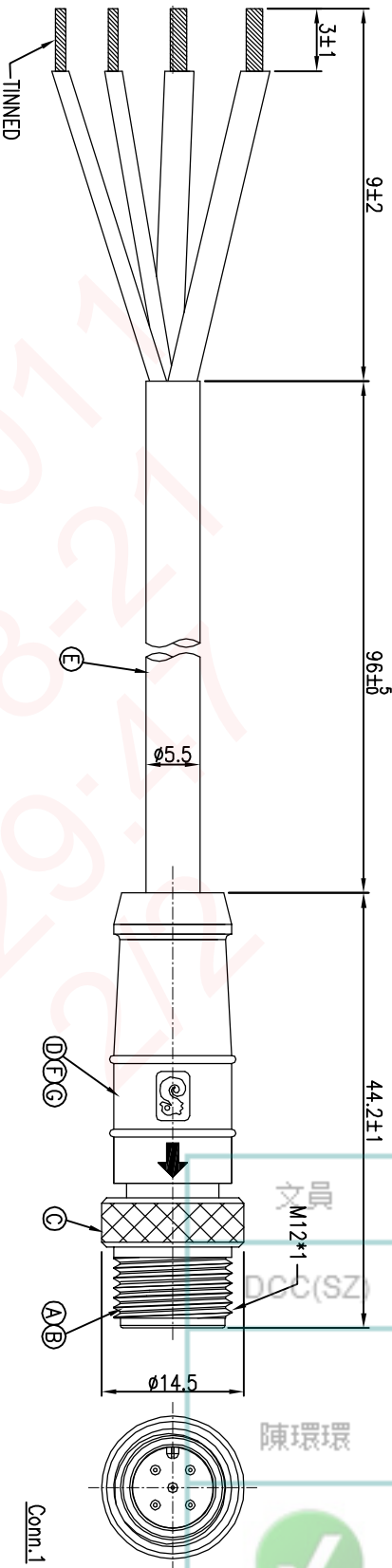

WATERPROOF RATE: IP67

5	BLACK(18#)
4	BROWN(24#)
3	/
2	ORANGE(24#)
1	RED(18#)
CONN.1 WIRE COLOR	
PIN OUT	

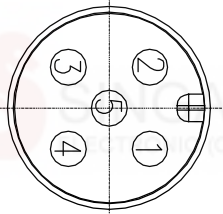

Pin Assignments
Front View

- NOTES:
1. WATERPROOF RATE: IP67
IP67: IMMERSED IN 1M WATER FOR 30 MINUTES
 2. CURRENT RATING: 5A
 3. SPECIFICATIONS:SEE "M12 SERIES SPECIFICATIONS".
 4. TO CONFORM TO THE SINGATRON HAZARDOUS SUBSTANCE FREE SPEC.
 5. GREEN PRODUCT IDENTIFICATION LABEL ON PACKAGING:

G	TUBE	5	φ2.5 (125;300V)	BLACK
F	INNER MOLD	1	TPU	BLACK
E	CABLE	1	UL2725 18#*2C+22#* 2C+AL OD5.5 UV	BLACK(PVC JACKET)
D	OVER MOLD	1	TPU	BLACK
C	SCREW NUT	1	BRASS	NICKEL PLATING
B	MALE PIN	5	BRASS	6u" GOLD PLATING OVER NICKEL PLATING
A	BODY	1	TPU	BLACK
NO	DESCRIPTION	QTY	MATERIAL	PLATING & COLOR
UNLESS OTHERWISE SPECIFIED TOLERANCES				
Singatron Enterprise Co., Ltd. 信晉企業股份有限公司				
TITLE M12 SERIES 180° 5 PIN MALE CONN.				
DWG	Harlan	PART NO.2MT3012-W05323H	SCALE 2:1	UNIT: mm
CHKD	JF			
APVD	STEVE	SIZE: A3	SHEET: 1 OF 1	REV: A

CUSTOMER COPY