

REV.	ECN NO.	OR DESCRIPTION	REVISED	DATE
A	PDR NO:1190627-2B		MF	2019.11.30

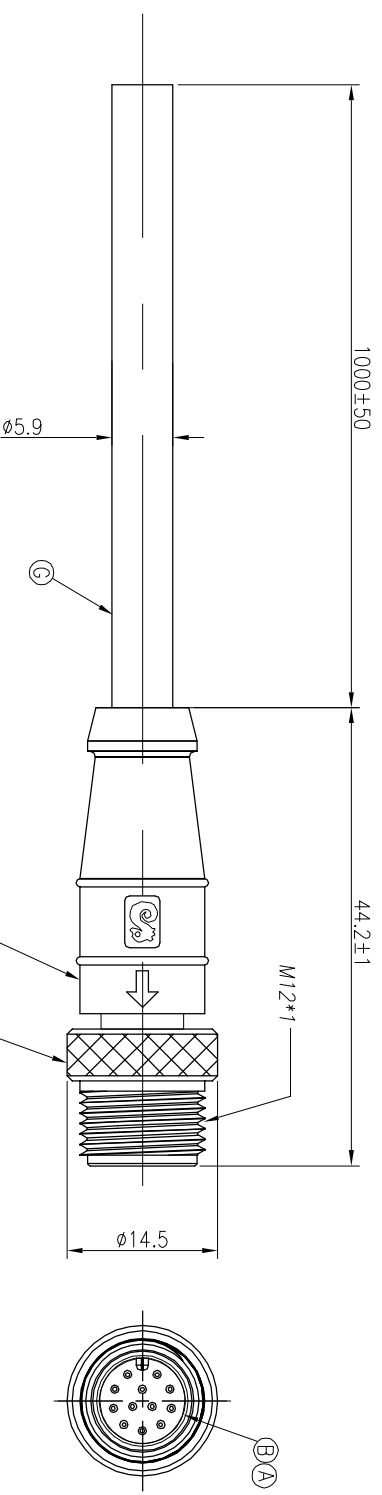

D	LIGHT GREEN	12
	PURPLE	11
	ORANGE	10
	BLACK	9
	RED	8
	PINK	7
	GREY	6
	YELLOW	5
	GREEN	4
	WHITE	3
	BLUE	2
	BROWN	1
B	WIRE COLOR	CONN.
	PIN OUT	

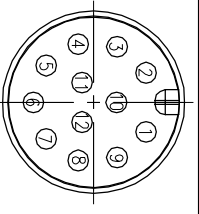

- NOTES:
1. WATERPROOF RATE: IP67
IP67: IMMERSED IN 1M WATER FOR 30 MINUTES
 2. RATING:30V 1A
 3. SPECIFICATIONS:SEE "M12 SERIES SPECIFICATIONS".
 4. TO CONFORM TO SINGATRON HAZARDOUS SUBSTANCE FREE SPEC.
 5. GREEN PRODUCT IDENTIFICATION LABEL ON PACKAGING: **G.P. PASS**

G	CABLE	1	PVC UL2464 26AWG*12C+AL	BLACK
F	HEAT SHRINK TUBE	12	Ø1.5mm 300V 125°C	BLACK
E	INNER MOLD	1	TPU	BLACK
D	OVER MOLD	1	TPU	BLACK
C	SCREW NUT	1	BRASS	BLACK NICKEL
B	MALE PIN	12	BRASS	GOLD PLATED OVER NICKEL PLATING
A	BODY	1	TPU	BLACK
NO	DESCRIPTION	QTY	MATERIAL	PLATING & COLOR

UNLESS OTHERWISE SPECIFIED TOLERANCES

 Singatron Enterprise Co., Ltd.
 信登企業股份有限公司

DECIMALS:	ANGLES:
X :±0.5	X :±2°
X.X :±0.3	X.X :±1°
X.XX :±0.2	

TITLE	M12 SERIES 180° 12PIN MALE CONN.
DWN	MF
CHKD	Cerry
APVD	William
PART NO.2MT3012-W12200H	
SCALE 2:1 UNIT: mm	
SIZE: A3 SHEET: 1 OF 1	
REV: A	

CUSTOMER COPY