

REV/ECN NO OR DESCRIPTION	REVISED	DATE
A PDR NO:5170810-3A	JF	2018.02.06

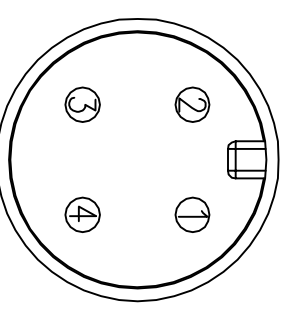
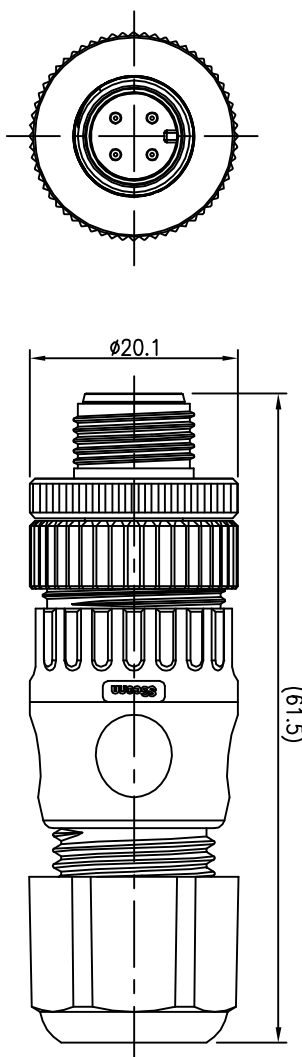
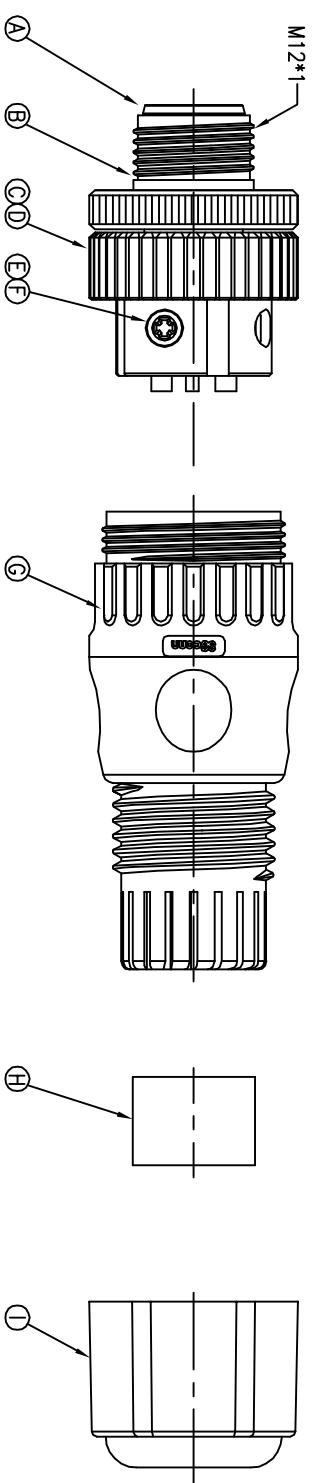

Pin Assignments
Front View

- NOTES:
- ELECTRICAL CHARACTERISTICS:
 - CURRENT RATING: 5 AMPS.
 - CONTACT RESISTANCE: 30 mOhm Max.
 - INSULATION RESISTANCE: 100 Mohm Min. at 500VDC.
 - BREAKDOWN VOLTAGE: 500 VAC PER MINUTE.
 - MECHANICAL CHARACTERISTICS:
 - CONTACT ACCOMMODATION: 18~22AWG.
 - TIGHTENING TORQUES: 1.0~1.2Nm(8.85~10.62lbf.in.).
 - ENVIRONMENTAL:
 - OPERATING TEMPERATURE: -40°C TO +105°C.
 - SEALING REQUIREMENTS: IP67.
 - CABLE ACCEPTANCE: 6.0~9.0mm.
 - LIFE TEST: 1,000 CYCLES MIN.
 - OTHER GENERAL SPEC. TO REFER "M12 SERIES SPEC."
 - FOR TECHNICAL DATA REFER TO YOUR LOCAL SINGATRON ELECTRONICS SALES OFFICE.
 - ALL DIMENSIONS ARE NOMINAL FOR REFERENCE ONLY UNLESS OTHERWISE STATED.
 - TO CONFORM TO SINGATRON HAZARDOUS SUBSTANCE FREE SPEC.
 - GREEN PRODUCT IDENTIFICATION LABEL ON PACKAGING: [Click Here](#).

1	SEALING NUT	1	PA66	BLACK
H	SEAL	1	EPDM	BLACK
G	CLAMP RING	1	PA66	N/A
F	SCREW	4	STEEL	N/A
E	MALE PIN	4	BRASS	6u" GOLD PLATING
D	O-RING	1	SILICONE	BLACK
C	SCREW NUT2	1	PA66	BLACK
B	SCREW NUT1	1	BRASS	NICKEL
A	BODY	1	PA66+GF	BLACK
NO	DESCRIPTION	QTY	MATERIAL	PLATING & COLOR
UNLESS OTHERWISE SPECIFIED TOLERANCES				
Singatron Enterprise Co., Ltd. 信營企業股份有限公司				
TITLE M12 SERIES SIZE (IP67)				
DWG JF MALE CONN. MALE SPIN ASSEMBLY TYPE				
PART NO. 2MT9033-W043B1H				
CHKD Jun SCALE 2:1 UNIT: mm				
APVD Steve SIZE: A3 SHEET: 1 OF 1 REV: A				
CUSTOMER COPY				