

REV.	ECN NO OR DESCRIPTION	REVISED	DATE
A	PDR NO:T140401-1A	JF	2015.09.25
B	ECN NO.:S171150-R	Jun	2017.11.21

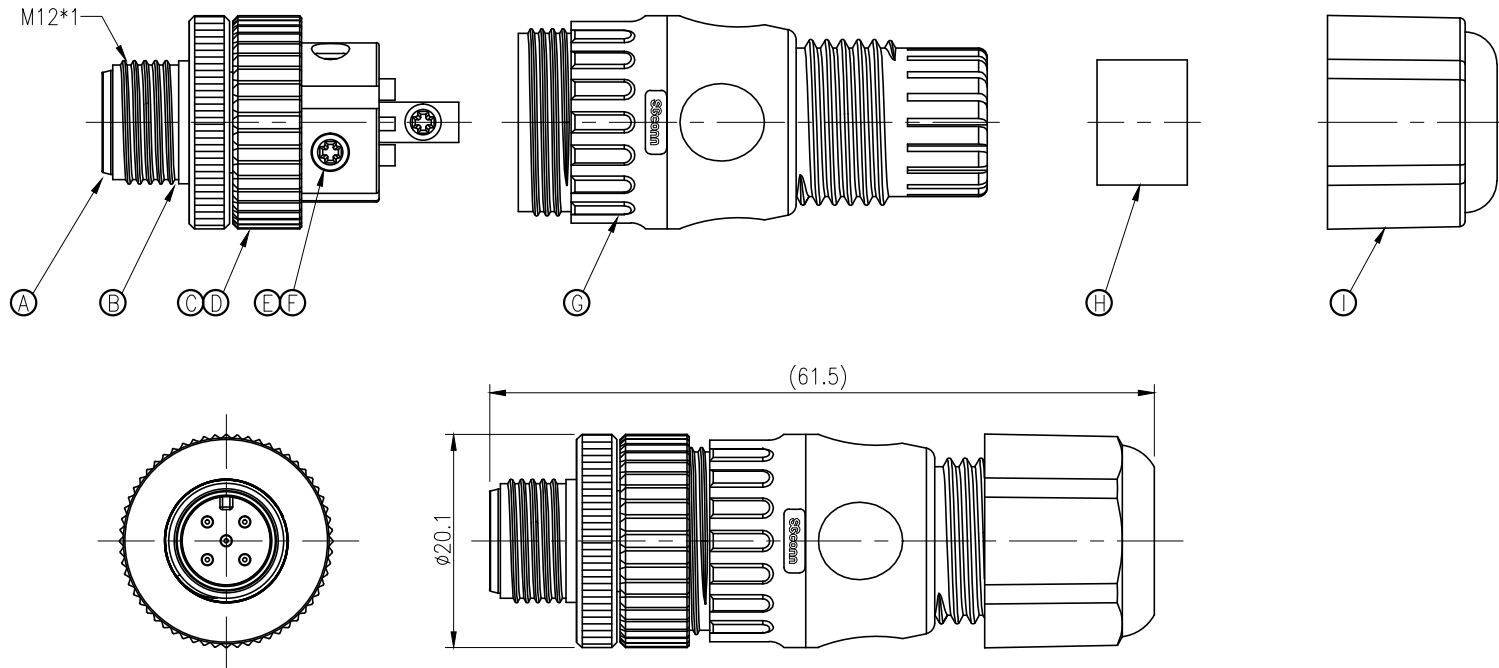

- NOTES:
- ELECTRICAL CHARACTERISTICS:
 - 1-1 CURRENT RATING: 5 AMPS.
 - 1-2 CONTACT RESISTANCE: 30 mOhm Max.
 - 1-3 INSULATION RESISTANCE: 100 MOhm Min. at 500VDC.
 - 1-4 BREAKDOWN VOLTAGE: 500 VAC PER MINUTE.
 - MECHANICAL CHARACTERISTICS:
 - 2-1 CONTACT ACCOMMODATION: 18~22AWG.
 - 2-2 TIGHTENING TORQUES: 1.0~1.2Nm(8.85~10.62lbf.in.).
 - ENVIRONMENTAL:
 - 3-1 OPERATING TEMPERATURE: -40°C TO +105°C.
 - 3-2 SEALING REQUIREMENTS: IP67.
 - CABLE ACCEPTANCE: 3.0~6.0mm.
 - LIFE TEST: 1,000 CYCLES MIN.
 - OTHER GENERAL SPEC. TO REFER "M12 SERIES SPEC."
 - FOR TECHNICAL DATA REFER TO YOUR LOCAL SINGATRON ELECTRONICS SALES OFFICE.
 - ALL DIMENSIONS ARE NOMINAL FOR REFERENCE ONLY UNLESS OTHERWISE STATED.
 - TO CONFORM TO SINGATRON HAZARDOUS SUBSTANCE FREE SPEC.
 - GREEN PRODUCT IDENTIFICATION LABEL ON PACKAGING: **G.P. PASS**

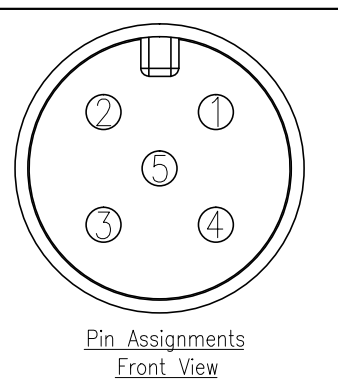

NO	DESCRIPTION	QTY	MATERIAL	PLATING & COLOR
I	SEALING NUT	1	PA66+GF	BLACK
H	SEAL	1	EPDM	BLACK
G	CLAMP RING	1	PA66+GF	N/A
F	SCREW	5	STEEL	N/A
E	MALE PIN	5	BRASS	5u" GOLD PLATING 20u" Pd Ni
D	O-RING	1	SILICONE	BLUE
C	SCREW NUT2	1	PA66+GF	BLACK
B	SCREW NUT1	1	BRASS	NICKEL
A	BODY	1	PA66+GF	BLACK

UNLESS OTHERWISE SPECIFIED TOLERANCES

DECIMALS: ANGLES:
 X :±0.5 X :±2°
 X.X :±0.3 X.X :±1°
 X.XX :±0.2

Singatron Enterprise Co., Ltd.
 信音企業股份有限公司

TITLE: M12 SERIES SIZE (IP67)
 MALE CONN. MALE 5PIN ASSEMBLY TYPE

DWN Jun PART NO. 2MT3033-W053B0H

CHKD Yang SCALE 2:1 UNIT: mm

APVD Steve SIZE: A3 SHEET: 1 OF 1 REV: B

CUSTOMER COPY