

REV.	ECN NO.	OR DESCRIPTION	REVISED	DATE
A	PDR NO:T110628-5A		Harfen	2011.7.22
B	ECN NO:S120336		Harfen	2012.3.16
B1	ECR NO:		Erod	2023.03.20

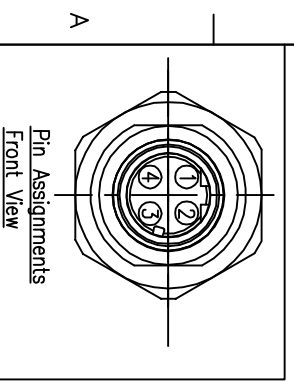
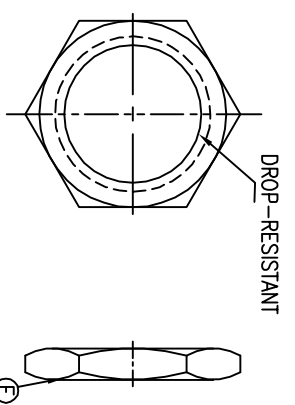
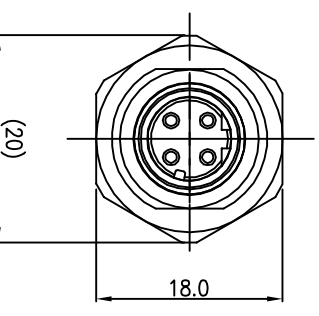
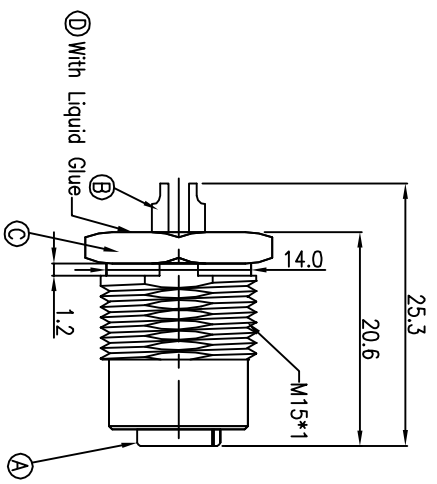
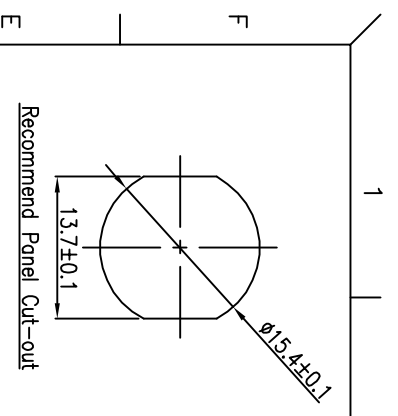

- NOTES:
1. WATERPROOF DEGREE OF PROTECTION: IP68.
  2. ELECTRICAL CHARACTERISTICS  
TEMPERATURE RANGE: -40°C TO +105°C(PANEL)  
RATING: 60V AC/DC 5A
  3. DIELECTRIC WITHSTANDING VOLTAGE: 500V AC FOR ONE MINUTE
  4. SPECIFICATIONS: SEE "M12 SERIES SPECIFICATIONS".
  5. TO CONFORM TO SINGATRON HAZARDOUS SUBSTANCE FREE SPEC.
  6. GREEN PRODUCT IDENTIFICATION LABEL ON PACKAGING:

E	NUT	1	BRASS DROP-RESISTANT NICKEL PLATING 100u"
D	LIQUID GLUE	1	BLACK
C	SHIELD	1	BRASS NICKEL PLATING 100u"
B	FEMALE PIN	4	Phosphor Bronze 6u" GOLD PLATING OVER NICKEL PLATING
A	BODY	1	NYLON+GF MATERIAL PLATING & COLOR BLACK
UNLESS OTHERWISE SPECIFIED TOLERANCES			
Suzhou Singatron Auto Electronics CO.,LTD. 苏州信音汽车电子有限公司			
TITLE: M12 D-CODED SERIES FRONT MOUNT FEMALE CONN. (4PIN) HEXAGONAL BACKSHELL			
DWN	Erod	PART NO. 2MT3D02-W04300H	
CHKD	Jun	SCALE 2:1 UNIT: mm	
APVD	Steve	SIZE: A3 SHEET: 1 OF 1	REV: B1

DECIMALS: ANGLES: X : ±0.5 X : ±2 X.X : ±0.3 X.X : ±1' X.XX : ±0.2

CUSTOMER COPY