

RoHS COMPLIANT

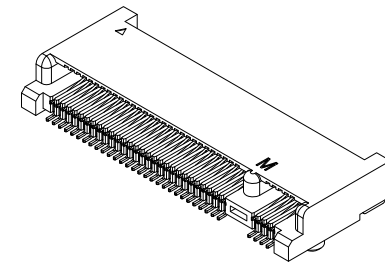
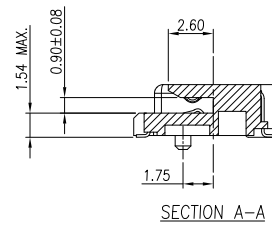
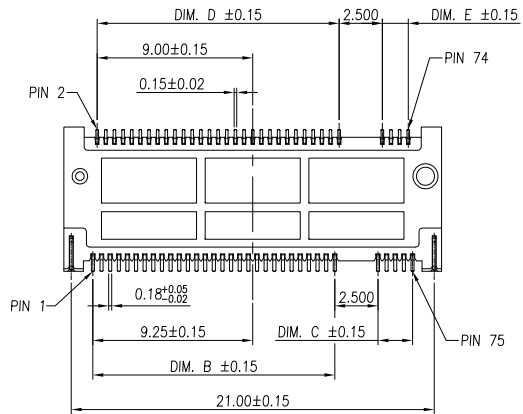
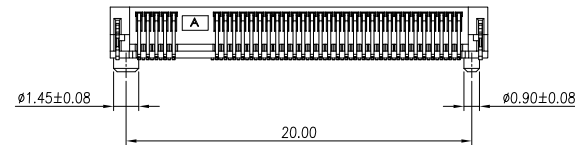
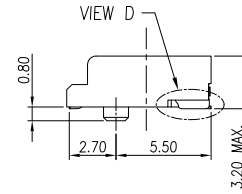
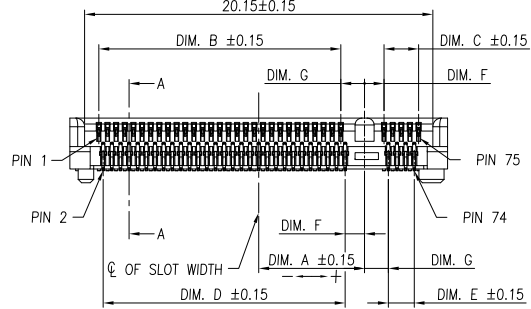
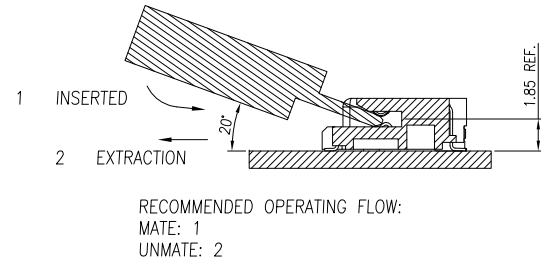
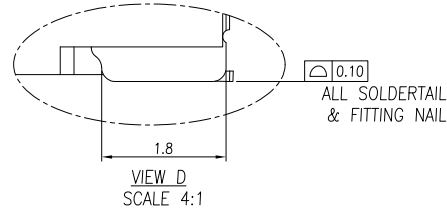
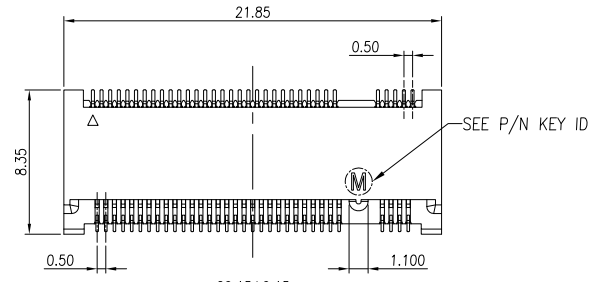

DIMENSIONS:  
 MM [INCH]    INCH [MM]    MM ONLY  
 UNLESS OTHERWISE SPECIFIED,  
 GENERAL TOLERANCE:  
 DECIMALS                      ANGLES  
 .X ±0.35                          X° ±3'  
 .XX ±0.25                        .X° ±1.0'  
 .XXX±0.15

<b>Singatron Enterprise Co., Ltd.</b>				
TITLE	M.2 CONN. 3.2mm H, GEN4			
DWN	Helly Luo	PART NO.	2NF-9130232067RXX	
CHKD	2022-07-29	SCALE 1:1	UNIT: mm	
APVD	JASON MENG	SIZE: A3	SHEET: 1 OF 5	REV: 1
<b>CUSTOMER COPY</b>				

RoHS COMPLIANT

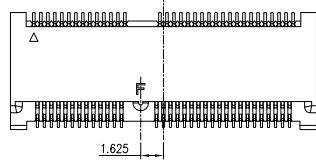
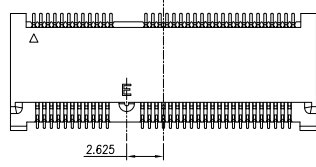
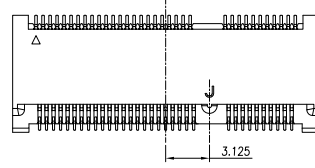
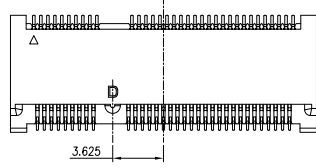
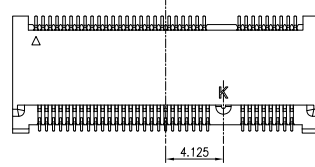
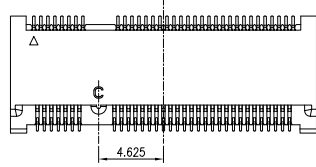
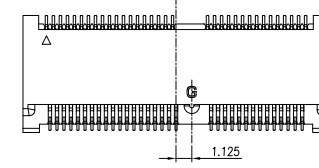
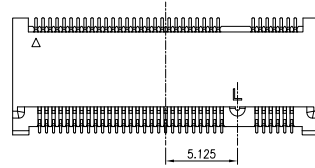
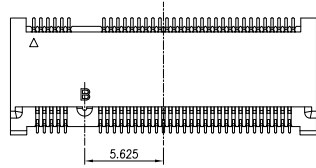
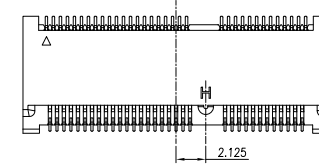
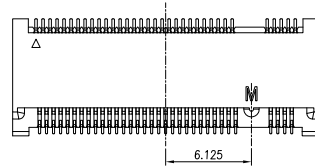
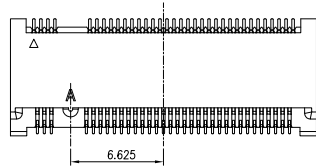

DIMENSIONS:  
 MM [INCH]     INCH [MM]     MM ONLY  
 UNLESS OTHERWISE SPECIFIED,  
 GENERAL TOLERANCE:  
 DECIMALS                      ANGLES  
 .X ±0.35                      X° ±3°  
 .XX ±0.25                     .X° ±1.0°  
 .XXX±0.15

<b>Singatron Enterprise Co., Ltd.</b>				
<i>TITLE</i>	M.2 CONN. 3.2mm H, GEN4			
<i>DWN</i>	Helly Luo	<b>PART NO.</b>	2NF-9130232067RXX	
<i>CHKD</i>	2022-07-29	<i>SCALE</i>	1:1	<i>UNIT:</i> mm
<i>APVD</i>	JASON MENG	<i>SIZE:</i>	A3	<i>SHEET:</i> 2 OF 5 <b>REV:</b> 1
<i>CUSTOMER COPY</i>				

RoHS COMPLIANT

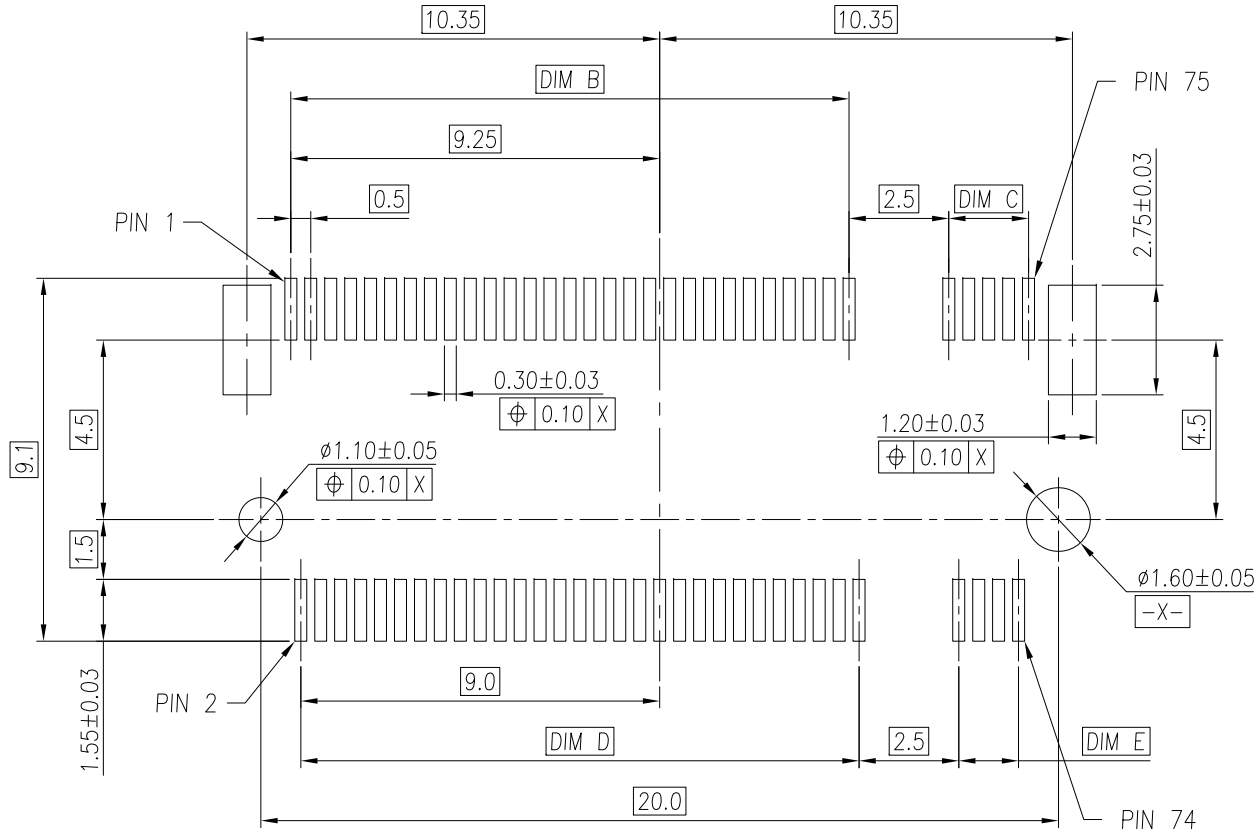

DIMENSIONS:  
 MM [INCH]     INCH [MM]     MM ONLY  
 UNLESS OTHERWISE SPECIFIED,  
 GENERAL TOLERANCE:  
 DECIMALS                      ANGLES  
 .X    ±0.35                      °    ±3°  
 .XX   ±0.25                      °    ±1.0°  
 .XXX ±0.15

<b>Singatron Enterprise Co., Ltd.</b>				
TITLE	M.2 CONN. 3.2mm H, GEN4			
DWN	Helly Luo	PART NO.	2NF-9130232067RXX	
CHKD	2022-07-29	SCALE	1:1	UNIT: mm
APVD	JASON MENG	SIZE: A3	SHEET: 3 OF 5	REV: 1
<b>CUSTOMER COPY</b>				

RoHS COMPLIANT

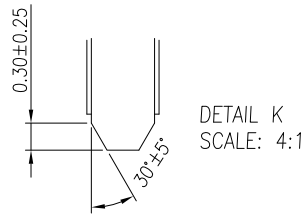
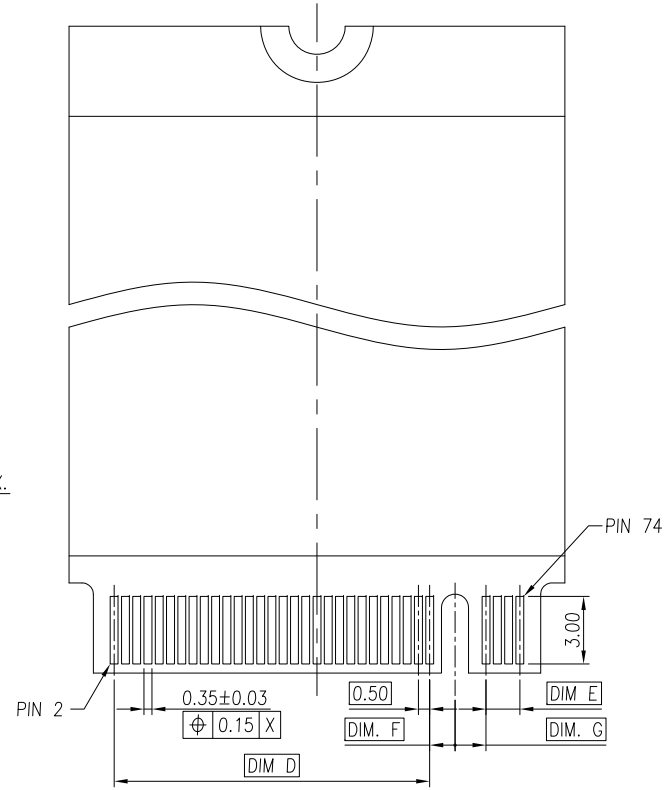
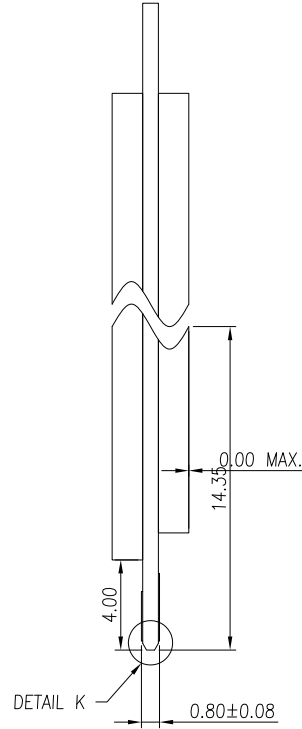
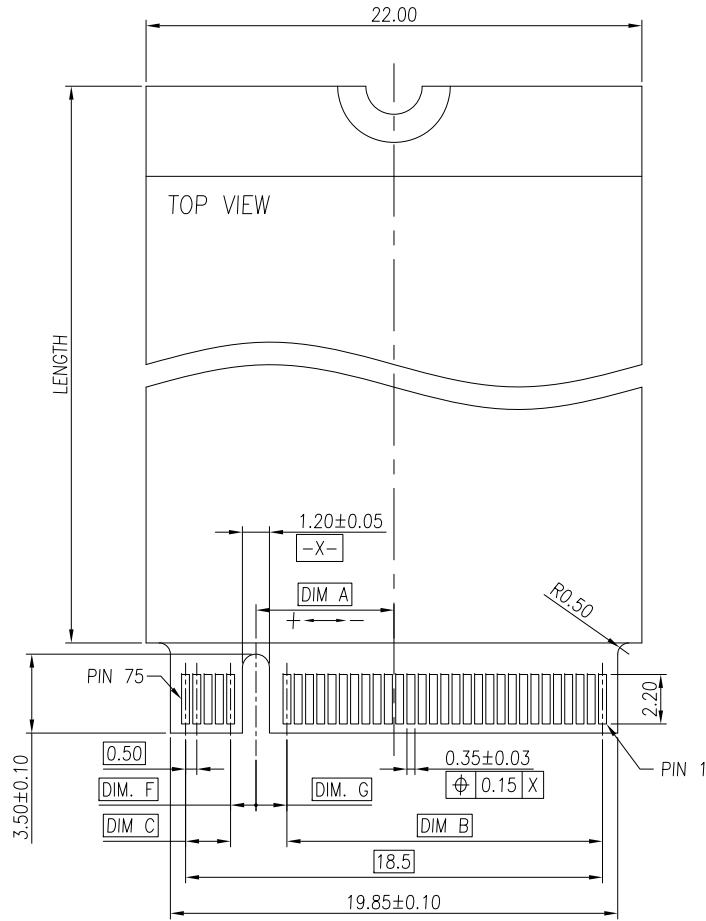

DETAIL K  
SCALE: 4:1

DIMENSIONS:

<input type="checkbox"/> MM [INCH]	<input type="checkbox"/> INCH [MM]	<input checked="" type="checkbox"/> MM ONLY
------------------------------------	------------------------------------	---

UNLESS OTHERWISE SPECIFIED,  
GENERAL TOLERANCE:

DECIMALS	ANGLES
.X ±0.35	X° ±3°
.XX ±0.25	.X° ±1.0°
.XXX ±0.15	

Singatron Enterprise Co., Ltd.

TITLE	M.2 CONN. 3.2mm H, GEN4		
DWN	Helly Luo	PART NO.	2NF-9130232067RXX
CHKD	2022-07-29	SCALE	1:1 UNIT: mm
APVD	JASON MENG	SIZE: A3	SHEET: 4 OF 5 REV: 1

CUSTOMER COPY

RoHS COMPLIANT

NOTES:

1. MATERIAL :
  - 1.1 HOUSING: THERMOPLASTIC, HIGH TEMPERATURE, UL94 V-0, COLOR: BLACK.
  - 1.2 CONTACT: COPPER ALLOY.
  - 1.3 FITTING NAIL: COPPER ALLOY.
2. FINISH :
  - 2.1 CONTACT
    - [SEE TABLE] GOLD PLATING ON THE CONTACT AREA.
    - GOLD FLASH PLATING ON THE SOLDERING AREA.
    - 1.27um~2.54um [50u"~100u"] MIN. NICKEL UNDERPLATING OVERALL.
  - 2.2 FITTING NAIL
    - 2.54um~5.08um [100u"~200u"] MIN. MATTE-TIN PLATING ON THE SOLDERING AREA.
    - 1.27um~2.54um [50u"~100u"] MIN. NICKEL UNDERPLATING OVERALL.

PART NO.:

2NF-9130232067R X X

PACKING OPTIONS  
R: TAPE & REEL

KEY ID OPTIONS  
A, B, C, D, E, F  
G, H, J, K, L, M

CONTACT AREA PLATING  
2: GOLD FLASH  
C: 15u" GOLD  
D: 30u" GOLD

1.375	1.125	1.5	14.0	2.0	14.0	6.125	M
1.375	1.125	2.5	13.0	3.0	13.0	5.125	L
1.375	1.125	3.5	12.0	4.0	12.0	4.125	K
1.375	1.125	4.5	11.0	5.0	11.0	3.125	J
1.375	1.125	5.5	10.0	6.0	10.0	2.125	H
1.375	1.125	6.5	9.0	7.0	9.0	1.125	G
DIM. G	DIM. F	DIM. E	DIM. D	DIM. C	DIM. B	DIM. A	KEY ID

1.125	1.375	9.5	6.0	9.5	6.5	-1.625	F
1.125	1.375	10.5	5.0	10.5	5.5	-2.625	E
1.125	1.375	11.5	4.0	11.5	4.5	-3.625	D
1.125	1.375	12.5	3.0	12.5	3.5	-4.625	C
1.125	1.375	13.5	2.0	13.5	2.5	-5.625	B
1.125	1.375	14.5	1.0	14.5	1.5	-6.625	A
DIM. G	DIM. F	DIM. E	DIM. D	DIM. C	DIM. B	DIM. A	KEY ID

DIMENSIONS:  
 MM [INCH]    INCH [MM]    MM ONLY  
 UNLESS OTHERWISE SPECIFIED,  
 GENERAL TOLERANCE:  
 DECIMALS                      ANGLES  
 .X ±0.35                      X° ±3'  
 .XX ±0.25                     .X° ±1.0'  
 .XXX±0.15

Singatron Enterprise Co., Ltd.

TITLE	M.2 CONN. 3.2mm H, GEN4			
DWN	Helly Luo	PART NO. 2NF-9130232067RXX		
CHKD	2022-07-29	SCALE 1:1	UNIT: mm	
APVD	JASON MENG	SIZE: A3	SHEET: 5 OF 5	REV: 1

CUSTOMER COPY