

REV: A	EGN NO: PDR	OR DESCRIPTION: RELEASE	REVISED: NY-C	DATE: 2014.09.03
--------	-------------	-------------------------	---------------	------------------

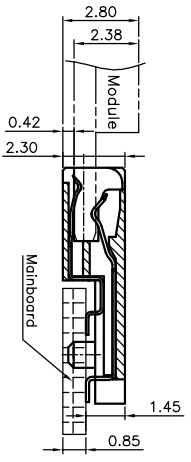
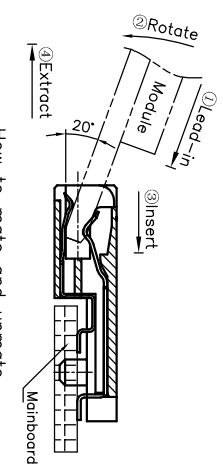
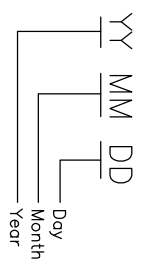
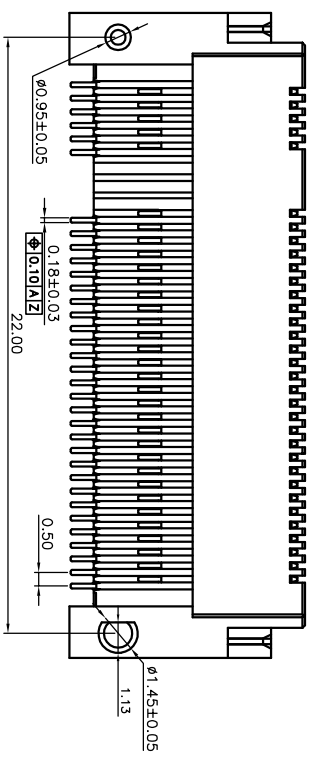
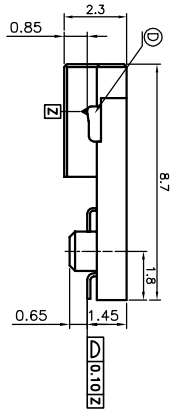
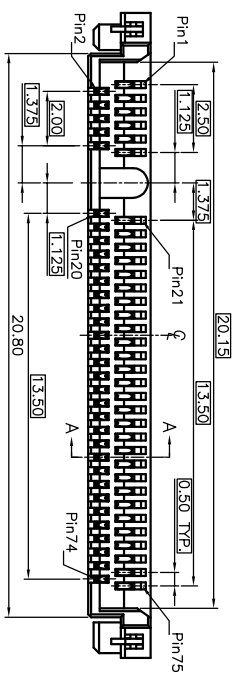
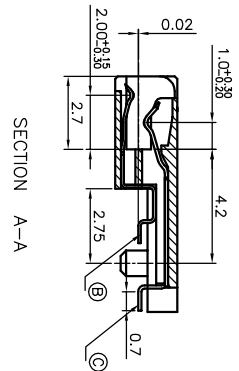
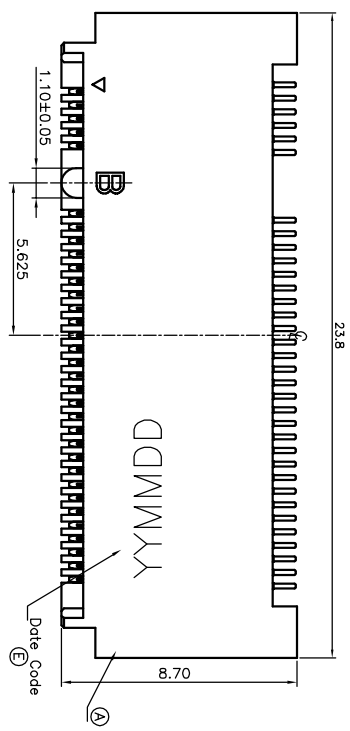

**SPECIFICATIONS:**

- ELECTRICAL CHARACTERISTICS:**
  - 1-1. CURRENT RATING: 0.5A(Per pin).
  - 1-2. VOLTAGE RATING: 50V AC(Per pin).
  - 1-3. LIGR: 55mΩ Max.(Initial), 20mΩ Max. change allowed(Final)
  - 1-4. INSULATION RESISTANCE: 500MΩ MIN. @ 500V DC.
  - 1-5. DIELECTRIC WITHSTANDING VOLTAGE: 300V AC FOR 1 MINUTE.
- MECHANICAL CHARACTERISTICS:**
  - 2-1. INSERTION FORCE: 20N MAX.
  - 2-2. WITHDRAWAL FORCE: 20N MAX.
3. LIFE TEST: 60 CYCLES.
4. TO CONFORM TO THE SINGATRON HAZARDOUS SUBSTANCE FREE SPEC.
5. HALOGEN FREE PRODUCT IDENTIFICATION LABEL ON PACKAGING.
6. PACKAGE: SEE "2NF1509 SERIES" PACKAGE.
7. FOR REFLOW SOLDERING LEAD-FREE PROCESS.
8. OTHER GENERAL SPEC. TO REFER "2NF1509 SERIES SPEC".

**PART NO.**

2NF1509-000111F

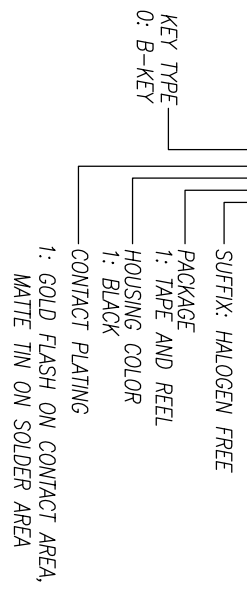

E	INK		BLACK
D	LEG	2 C2680-EH 0.20t	MATTE TIN PLATING, ALL OVER NICKEL
C	Upper CONTACT	34 C6210-SH 0.12t	SEE PART NO.
B	Lower CONTACT	33 C6210-SH 0.10t	SEE PART NO.
A	HOUSING	1 LCP E471; GF; UL94 V-0	BLACK
NO	DESCRIPTION	QTY	MATERIAL
UNLESS OTHERWISE SPECIFIED TOLERANCES			
DECIMALS: ANGLES: TITLE NGFF Socket (M.2 Connector) 1.45H STD B key			
X	:±0.5	X	:±2°
X.X	:±0.3	X.X	:±1°
X.XX	:±0.2		
APVD	ANCE401(1.000)	SIZE: A3	SHEET: 1 OF 2 REV: A

Singatron Enterprise Co., Ltd.  
信登企業股份有限公司

CUSTOMER COPY

REV.	ECN NO.	OR DESCRIPTION	REVISED	DATE
A	PDR RELEASE		WY-C	2014.09.03

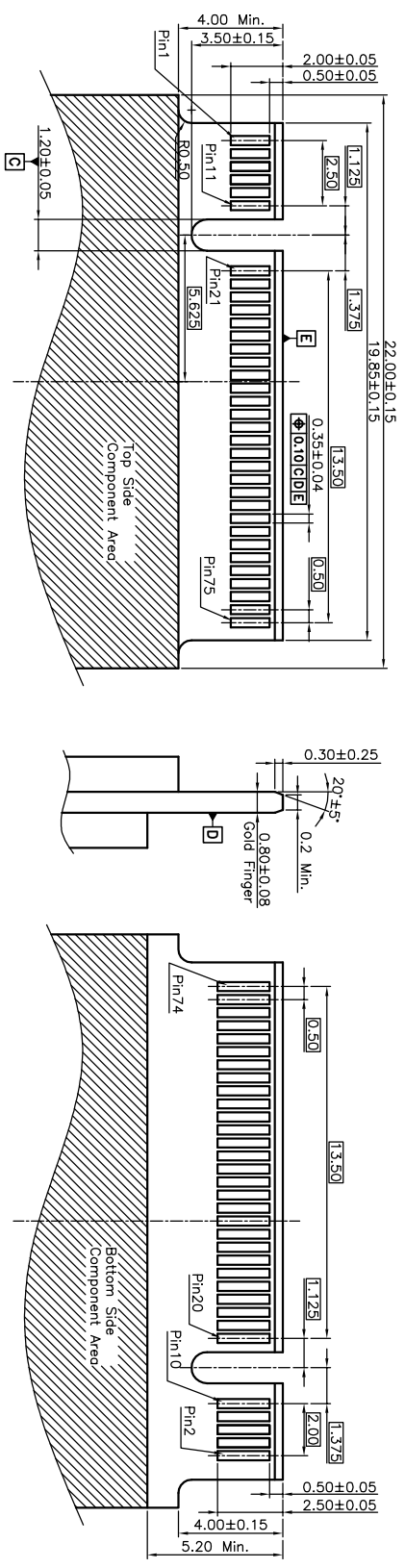

Recommended Mould Finger Layout

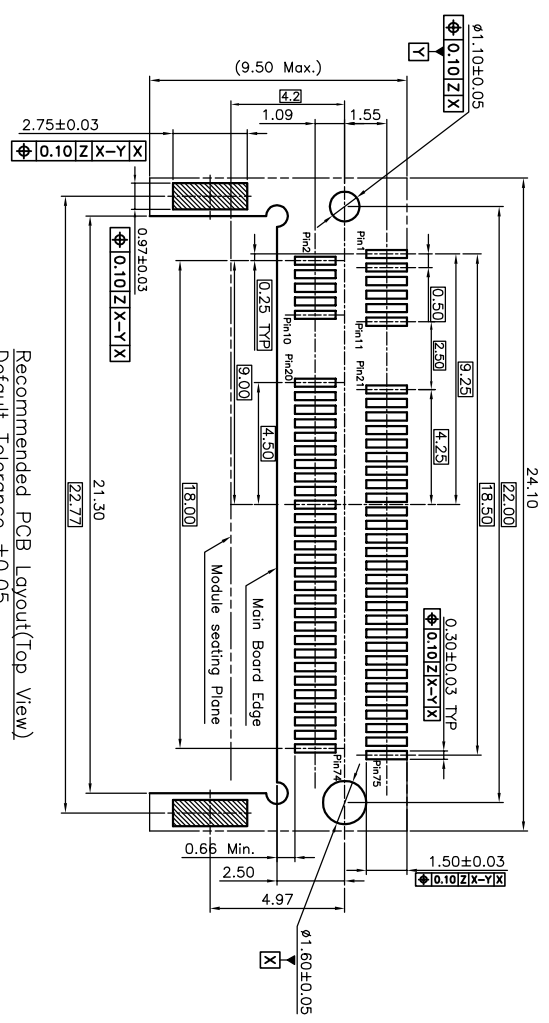

Recommended PCB Layout(Top View)  
Default Tolerance ±0.05

NO	DESCRIPTION	QTY	MATERIAL	PLATING & COLOR
	UNLESS OTHERWISE SPECIFIED TOLERANCES			
	DECIMALS:		ANGLES:	
X	:±0.5	X	:±2°	
X.X	:±0.3	X.X	:±1°	
X.XX	:±0.2			
	TITLE	NGFF Socket (M.2 Connector) 1.45H STD B key		
	DWN	W-C 2014.08.03	PART NO.	2NF1309-000111F
	CHKD		SCALE	N/A UNIT: mm
	APVD	ANGELAD014.08.03	SIZE:	A3 SHEET: 2 OF 2 REV: A

CUSTOMER COPY

Singatron Enterprise Co., Ltd.  
信亨企業股份有限公司