

REV.	ECN NO OR DESCRIPTION	REVISED	DATE
A	PDR NO: T120814-9A	Dak	2013.10.09

- SPECIFICATIONS:
- ELECTRICAL CHARACTERISTICS:
 - CURRENT : 0.5A PER PIN.
 - LICR: INITIAL: 55 mΩ MAX;
FINAL: ΔLICR=20 mΩ MAX;
 - MECHANICAL CHARACTERISTICS:
 - TERMINAL'S RETENSION FORCE TO BE 0.2KG/PIN MIN.
 - DURABILITY: 25 CYCLES.
 - IR REFLOW:
 - THE TEMPERATURE SHALL BE 260±5°C MAINTAINING 10±1 SECONDS.
 - TO CONFORM TO SINGATRON HAZARDOUS SUBSTANCE FREE SPEC.
 - HALOGEN PRODUCT IDENTIFICATION MARK ON JACK: Ⓢ
 - HALOGEN PRODUCT IDENTIFICATION LABEL ON PACKAGING: Ⓢ
 - DATE : YYMMDD-
 - PACKAGING : TAPE & REEL

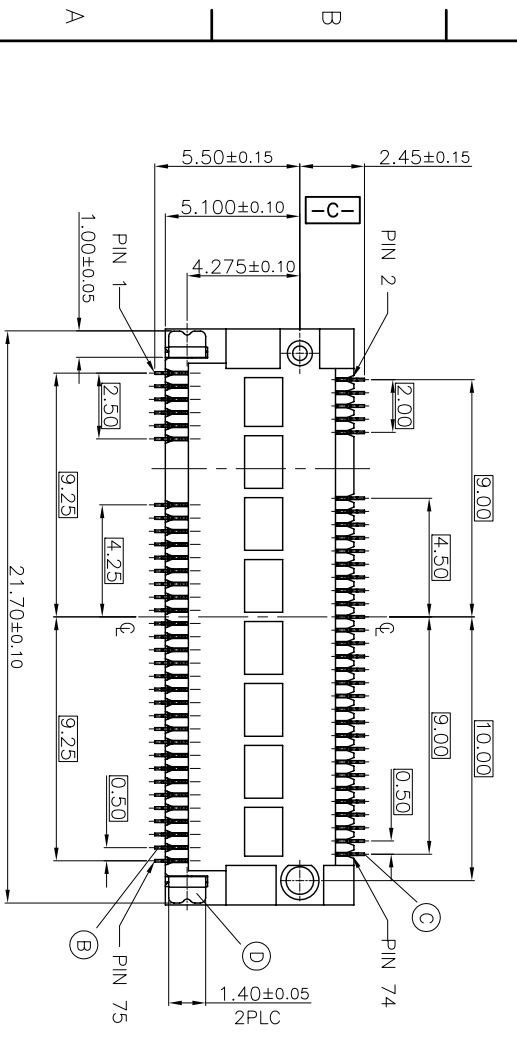
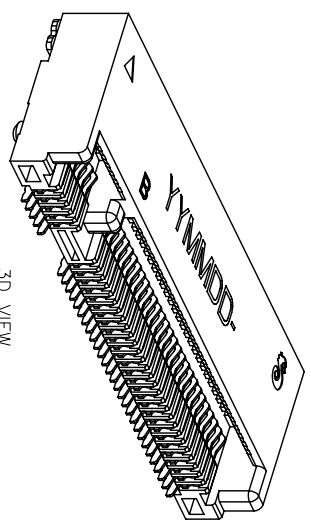
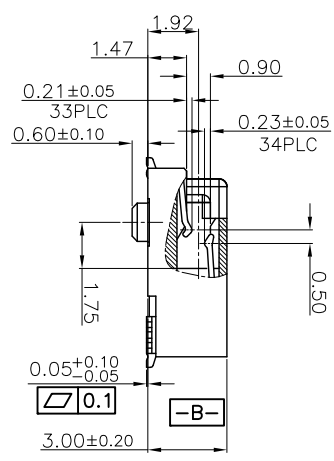
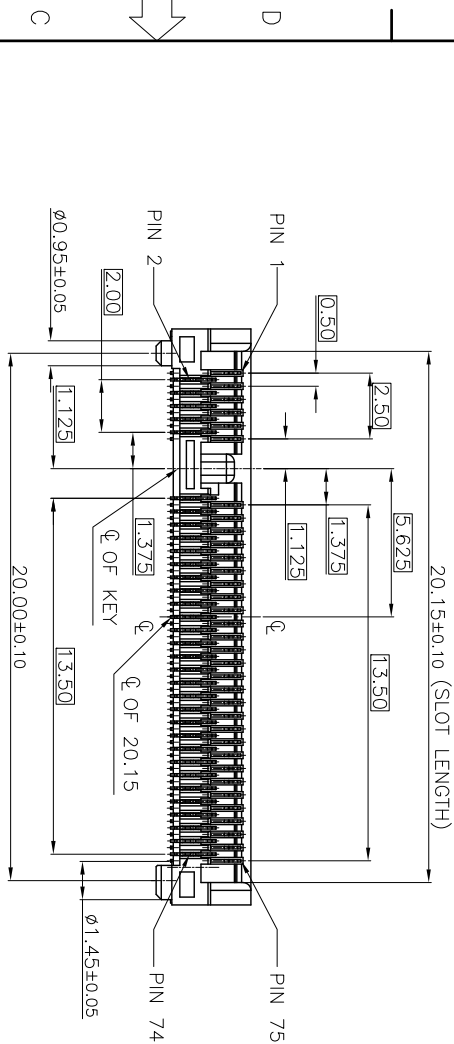
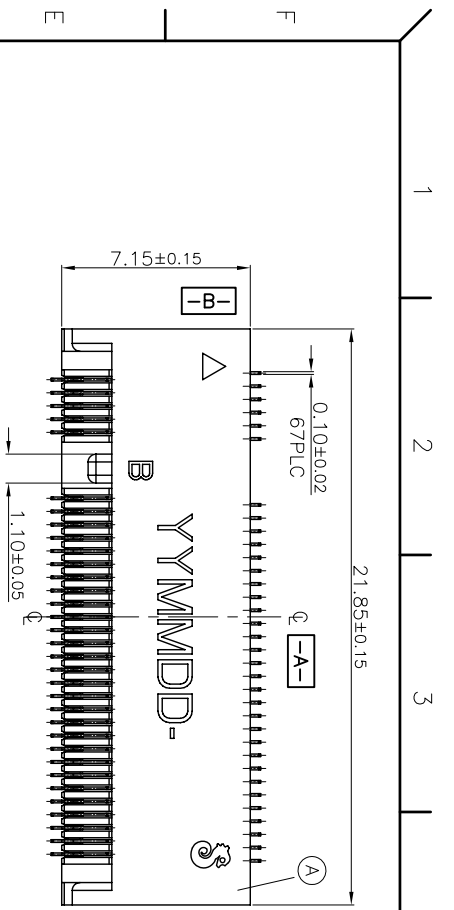

NO	DESCRIPTION	QTY	MATERIAL	PLATING & COLOR
D	FITTING NAIL	2	BARSS,T=0.20	Mat: Sn 100µm PLATED ON ALL AREA- ALL OVER 50µm NICKET PLATING.
C	D-TERMINAL	33	COPPER ALLOY, T=0.15	Mat: Sn 100µm OVER PLATED ON CONTACT AREA.
B	U-TERMINAL	34	COPPER ALLOY, T=0.15	Mat: Sn 100µm PLATED ON SOLDERING ALL OVER 50µm NICKET PLATING.
A	BODY	1	HIGH TEMP THERMOPLASTIC	BLACK

UNLESS OTHERWISE SPECIFIED TOLERANCES		信晉企業股份有限公司 Singatron Enterprise Co., Ltd.	
DECIMALS:	ANGLES:	NEPF 0.5 PITCH MINI PGT-B TOP MOUNT-DOUBLE SIDED(KEY B)	
X : ±0.5	X : ±2°	DWN	Dak
X.X : ±0.3	X.X : ±1°	CHKD	Boye
X.XX : ±0.2		APVD	
		SIZE: A3	SHEET: 1 OF 4
		REV: A	

CUSTOMER COPY

REV.	ECN NO.	OR DESCRIPTION	REVISED	DATE
A	PDR NO: T120814-9A	Dsk	2013.10.09	

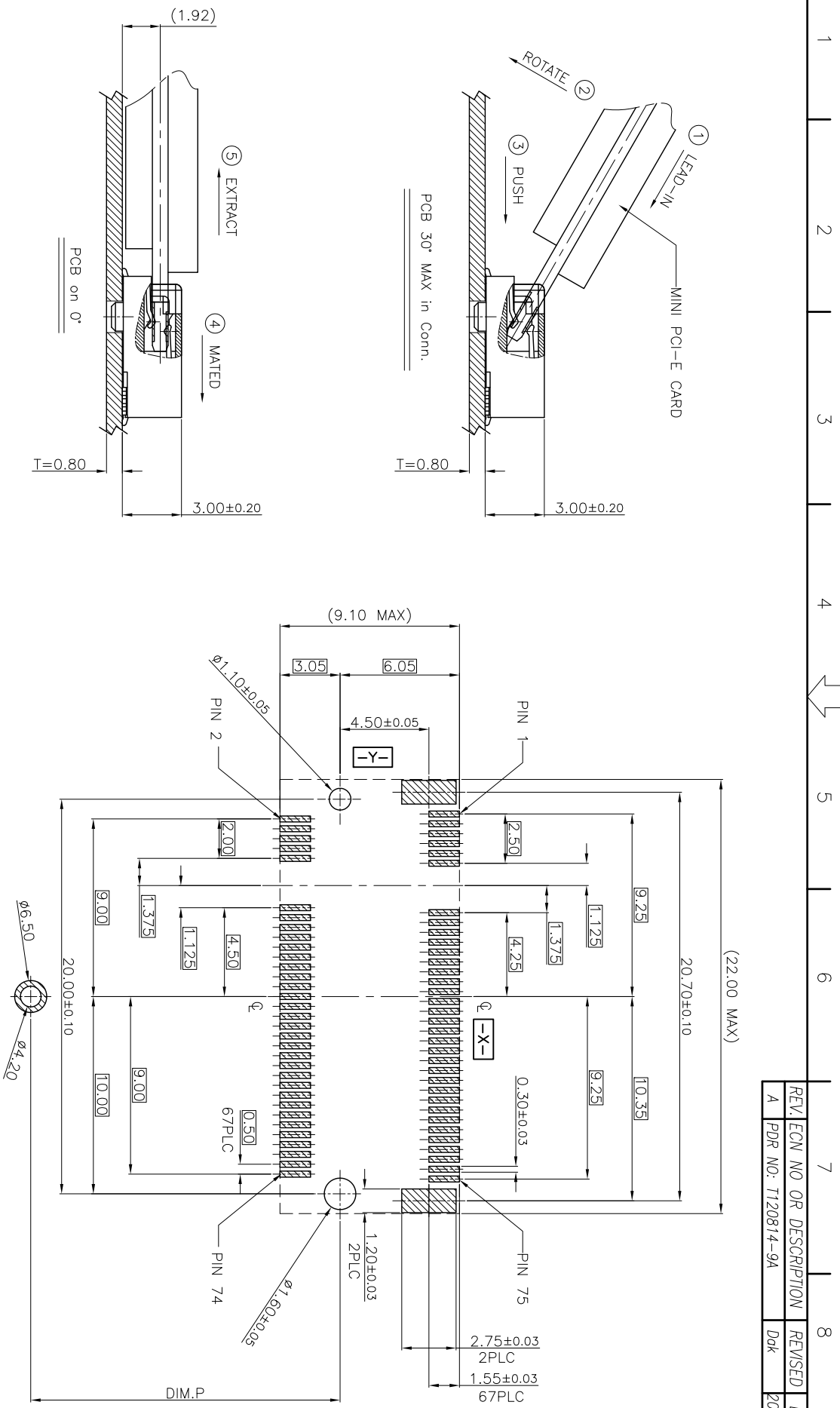

NO	DESCRIPTION	QTY	MATERIAL	PLATING & COLOR
22110	108.25			
2280	78.25			
2260	58.25			
2242	40.25			
2242	40.25			
3030	28.25			
2230	28.25			
TYPE	DIM.P			

DECIMALS:	ANGLES:
X : ±0.5	X : ±2°
X.X : ±0.3	X.X : ±1'
X.XX : ±0.2	

TITLE	PART NO:	UNIT:	REVISION:
DWN	2NFR3001-000111F	mm	4
CHKD	Boye		
APVD	SIZE: A3	SHEET: 2 OF 4	REV: A

CUSTOMER COPY

Singaton Enterprise Co., Ltd.
 信音企業股份有限公司
 NCFE 0.5 PITCH MINI PCI-E
 TOP MOUNT-DOUBLE SIDED(KEY B)

REV.	ECN NO OR DESCRIPTION	REVISED	DATE
A	PDR NO: T120814-9A	Dak	2013.10.09

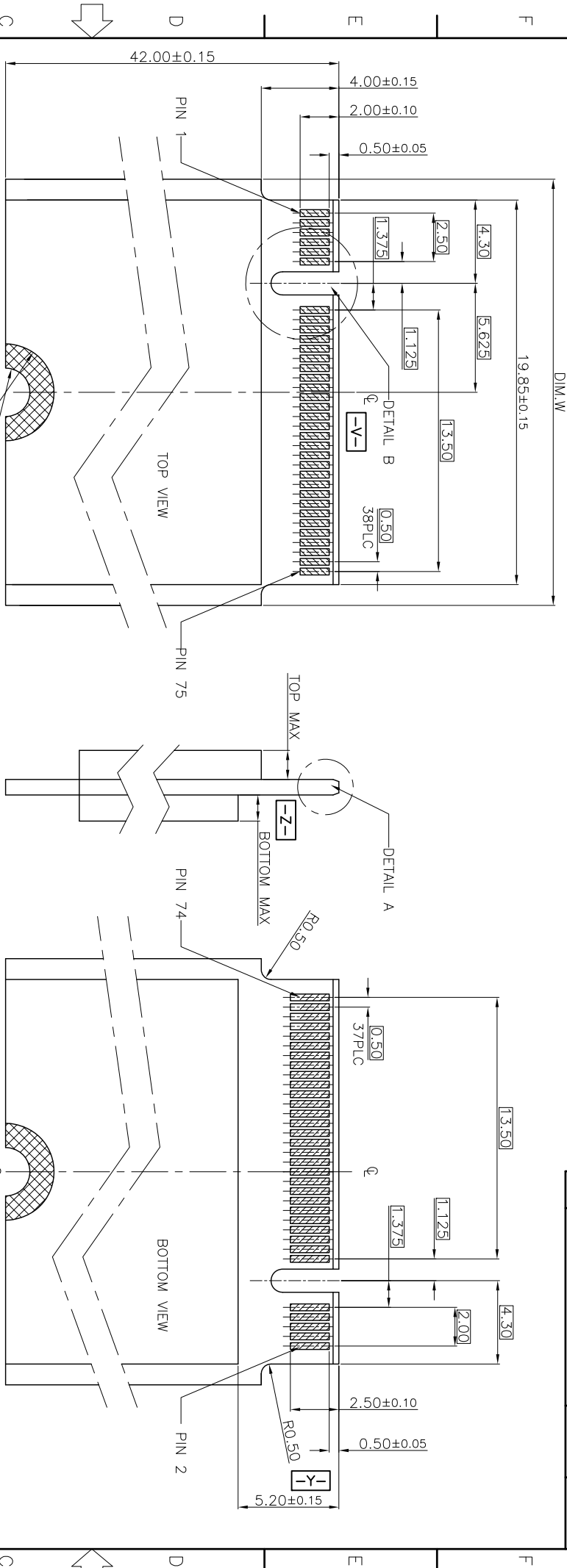

Width(mm)	22
DIM.W	30

Length(mm)	30
DIM.L	42
	60
	80
	110

Component	MAX H
D1	1.20
D2	1.35
D3	1.35
D4	1.5

CARD TYPE: XX XX - XX - X

KEY ID

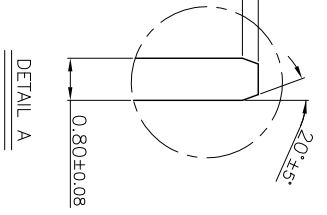
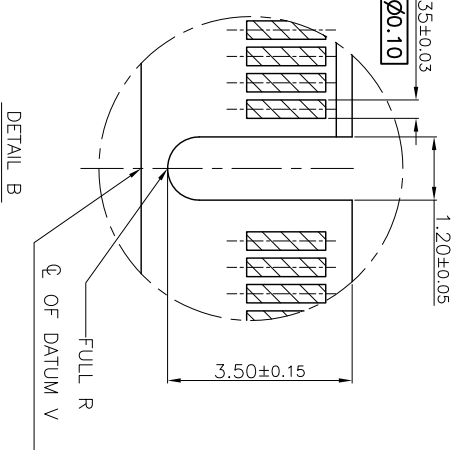

NO	DESCRIPTION	QTY	MATERIAL	PLATING & COLOR
	UNLESS OTHERWISE SPECIFIED TOLERANCES			
	DECIMALS:		ANGLES:	
X	:±0.5	X	:±2°	
X.X	:±0.3	X.X	:±1°	
X.XX	:±0.2			
	TITLE		NCP 0.5 PITCH MINI PGT-B	
	DWN		TOP MOUNT-DOUBLE SIDED(KEY B)	
	CHKD		Boye	SCALE:4:1
	APVD		SIZE: A3	SHEET:3 OF 4
				REV: A

CUSTOMER COPY

REV.	ECN NO.	OR DESCRIPTION	REVISED	DATE
A	PDR NO: T120814-9A		Dok	2013.10.09

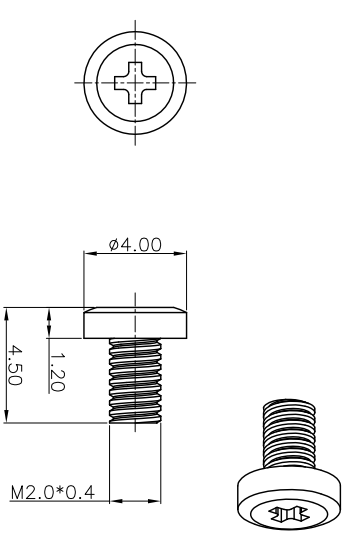
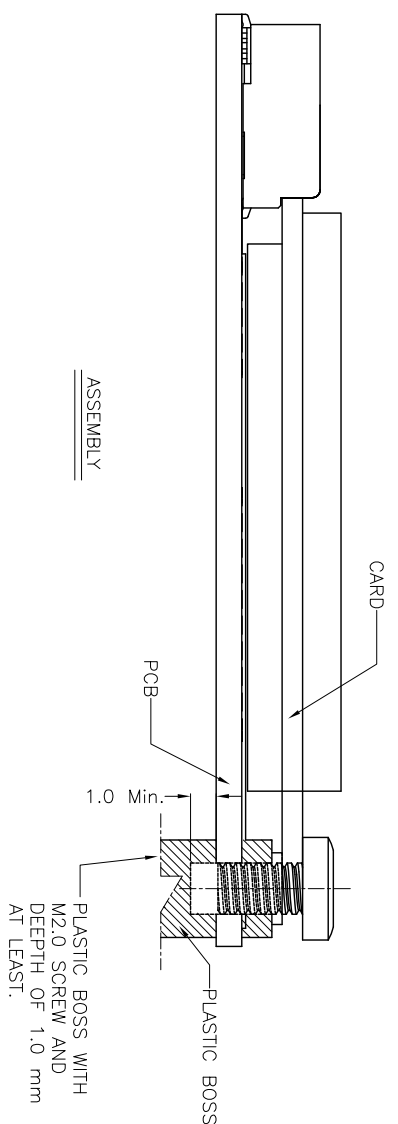
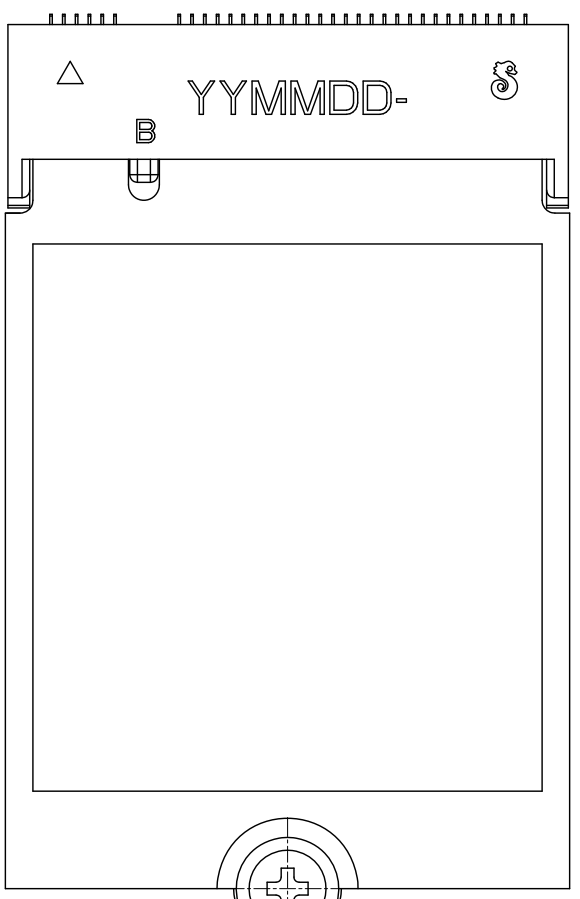

TITLE	SCREW
MATERIAL	STAINLESS STEEL(SUS304)

NO	DESCRIPTION	QTY	MATERIAL	PLATING & COLOR
UNLESS OTHERWISE SPECIFIED TOLERANCES				
DECIMALS:	ANGLES:			
X : ±0.5	X : ±2°			
X.X : ±0.3	X.X : ±1'			
X.XX : ±0.2				
TITLE	Singatron Enterprise Co., Ltd. 信音企業股份有限公司 NGPR 0.5 PITCH MINI PCI-B TOP MOUNT-DOUBLE SIDED(KEY B)			
DWN	Dok	PART NO: 2NF3001-000111F		
CHKD	Boye	SCALE:4:1 UNIT: mm		
AP/VD	SIZE: A3	SHEET:4 OF 4 REV: A		

ASSEMBLY

1 2 3 4 5 6 7