

- SPECIFICATIONS:
1. ELECTRICAL CHARACTERISTICS:
- 1-1. CURRENT : 0.5A PER PIN.
  - 1-2. LCCR: INITIAL: 55 mΩ MAX;  
FINAL: ΔLCCR=20 mΩ MAX;
2. MECHANICAL CHARACTERISTICS:
- 2-1. TERMINAL'S RETENSION FORCE TO BE 0.2KG/PIN MIN.
3. DURABILITY: 25 CYCLES.
4. IR REFLOW:
- THE TEMPERATURE SHALL BE 260±5°C MAINTAINING 10±1 SECONDS.
5. TO CONFORM TO SINGATRON HAZARDOUS SUBSTANCE FREE SPEC.
6. HALOGEN PRODUCT IDENTIFICATION MARK ON JACK: Ⓢ
7. HALOGEN PRODUCT IDENTIFICATION LABEL ON PACKAGING: Ⓢ
8. DATE : YYMMDD-
9. PACKAGING : TAPE & REEL

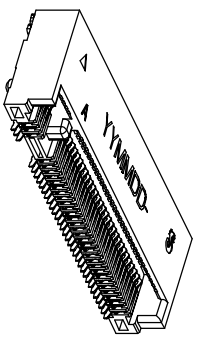

3D VIEW

REV.	ECN NO OR DESCRIPTION	REVISED	DATE
A	PDR NO: T130807-3A	Dok	2014.06.04
B	ECN NO: S140674	ERIC	2014.10.22

D	PAD	2	BARSS,T=0.20	Matl: Sn 100um FLATED ON ALL AREA; ALL OVER 50um NICKEL PLATING.
C	D-TERMINAL	33	COPPER ALLOY, T=0.10	
B	U-TERMINAL	34	COPPER ALLOY, T=0.10	GOLD FLASH ON CONTACT AREA AND SOLDER AREA ALL OVER IN 80UM.
A	BODY	1	HIGH TEMP. THERMOPLASTIC	BLACK
NO DESCRIPTION		MATERIAL PLATING & COLOR		
UNLESS OTHERWISE SPECIFIED TOLERANCES				
DECIMALS:		ANGLES:		
X.X :±0.5		X :±2°		
X.XX :±0.3		X.X :±1°		
X.XXX :±0.2				
Singatron Enterprise Co., Ltd. 信晉企業股份有限公司 NCF MINI Pci CONNECTOR H=3.0mm(KEY A)				
TITLE		PART NO: 2NF3001-001111F		
DWN ERIC		SCALE:4:1 UNIT: mm		
CHKD BOYE		SIZE: A3 SHEET:1 OF 4 REV: B		
APVD LIAO		CUSTOMER COPY		

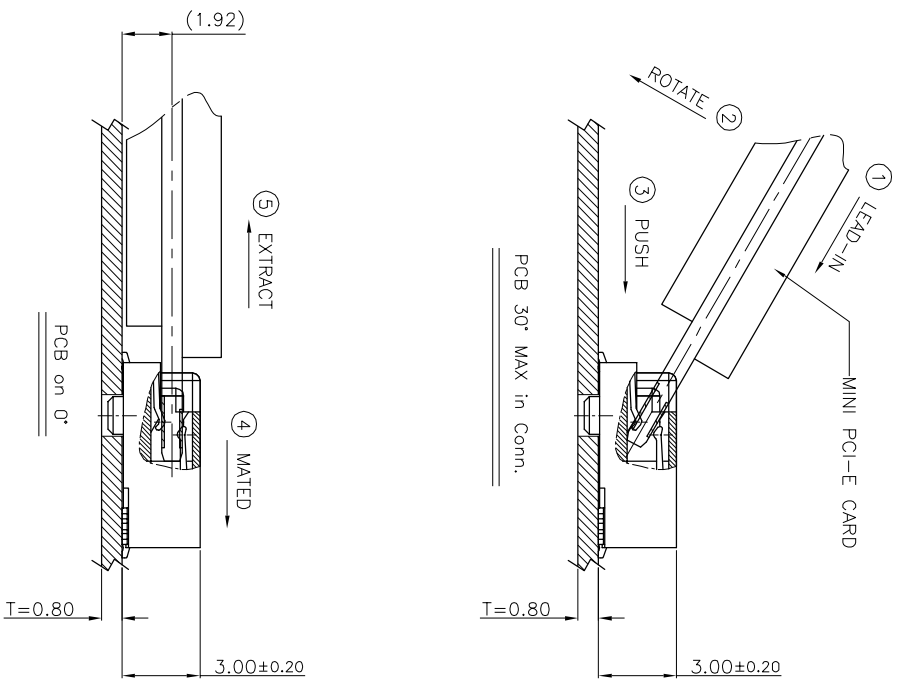

HOW TO MATE AND UNMATE

MATING FORCE WILL GENERATE FROM STEP 3 TO STEP 4

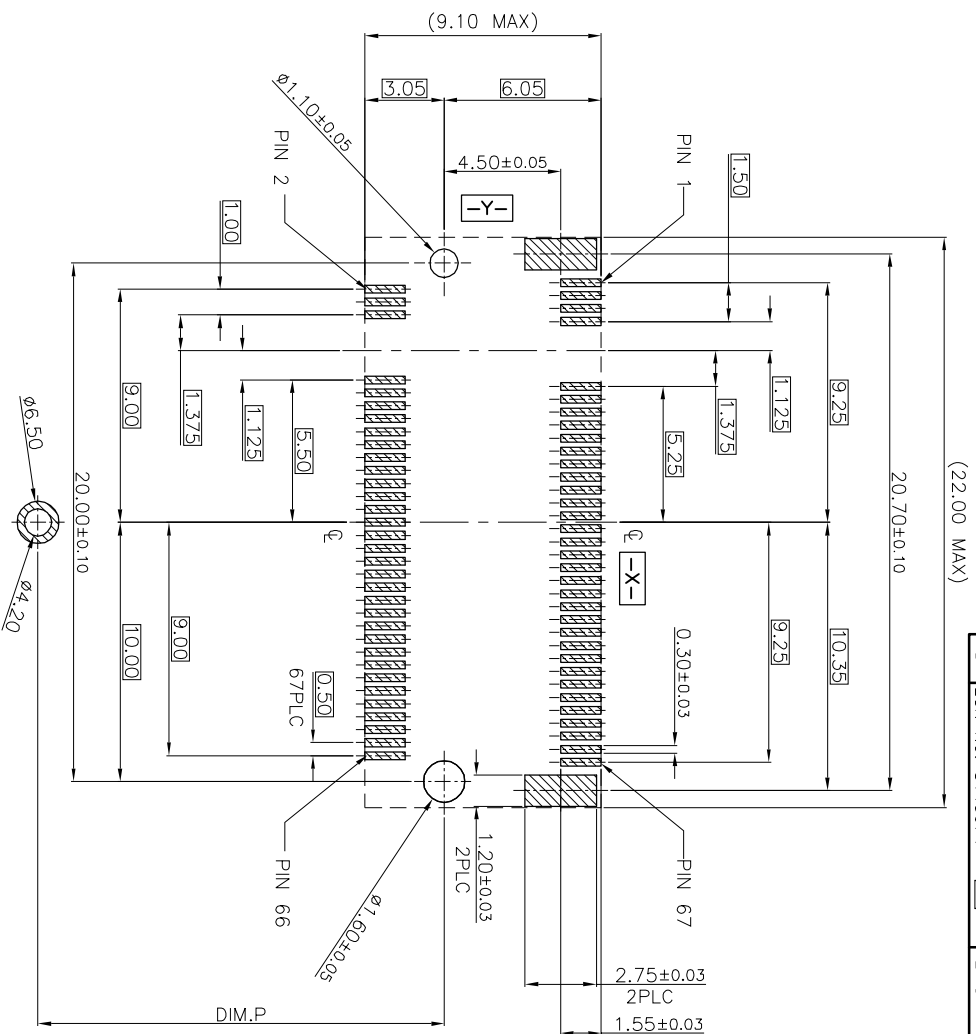

RECOMMENDED PCB LAYOUT(TOP VIEW)  
DEFAULT TOLERANCE ±0.05MM

NO	DESCRIPTION	QTY	MATERIAL	PLATING & COLOR
22110	UNLESS OTHERWISE SPECIFIED TOLERANCES	108,25		
2280		78,25		
2260		58,25		
2242	DECIMALS:	40,25		
2242	ANGLES:	40,25		
3030	X : ±0.5 X : ±2°	28,25		
2230	X.X : ±0.3 X.X : ±1°	28,25		
	X.XX : ±0.2			
	TYPE		DIM.P	

  

TITLE	PART NO:	SCALE:	UNIT:	SHEET:	REV:
DWN ERIC	2NPF3001-001111F	4:1	mm	2 OF 4	B
CHKD BOYE					
APVD LIAO		A3			

REV.	ECN NO OR DESCRIPTION	REVISED	DATE
A	PDR NO: T130807-3A	Dok	2014.06.04
B	ECN NO: S140674	ERIC	2014.10.22

Singatron Enterprise Co., Ltd.  
信譽企業股份有限公司  
NGFF MINI PCI CONNECTOR  
H=3.0mm(KEY A)PART NO: 2NPF3001-001111F  
SCALE: 4:1  
UNIT: mm  
SIZE: A3  
SHEET: 2 OF 4  
REV: B  
CUSTOMER COPY

REV.	ECN NO OR DESCRIPTION	REVISED	DATE
A	PDR NO: T130807-3A	Dok	2014.06.04
B	ECN NO: S140674	ERIC	2014.10.22

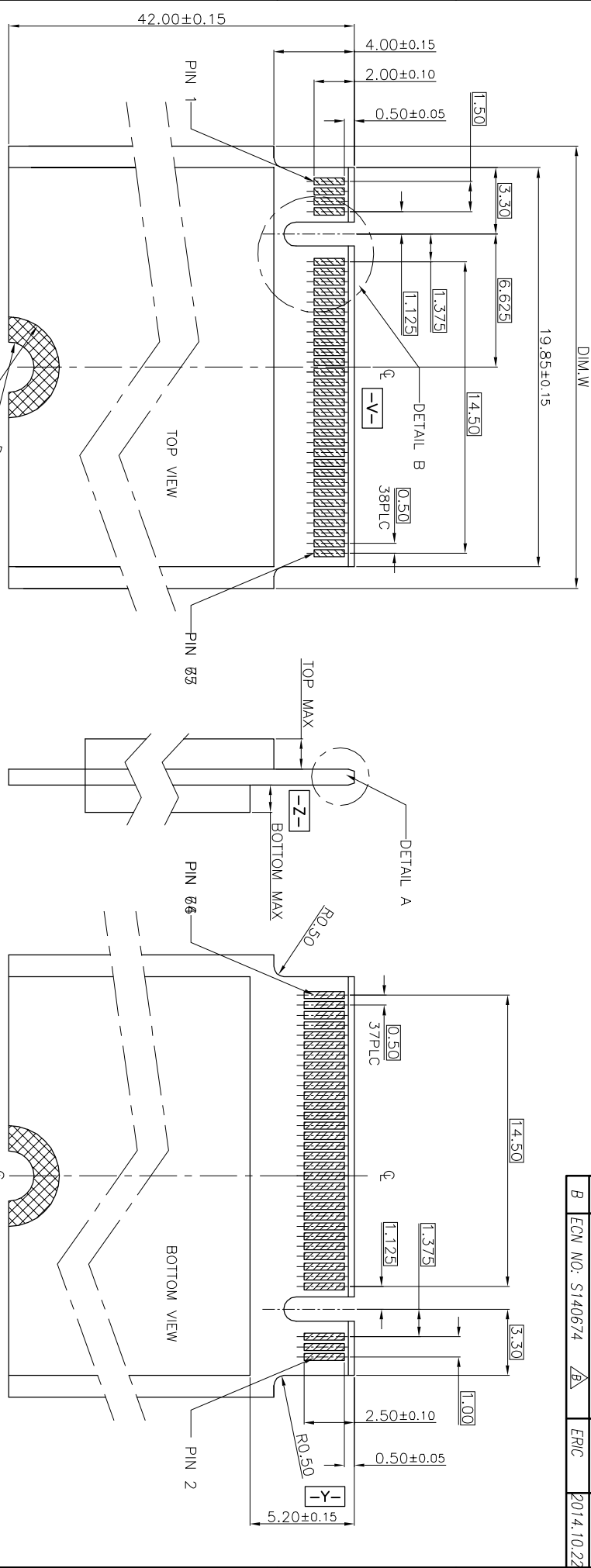

Width(mm)	22
DIM:W	30

Length(mm)	30
DIM:L	42
	60
	80
	110

Component	MAX H	
	Top	Bottom
D1	1.20	1.35
D2	1.35	1.35
D3	1.5	1.35
D4	1.5	1.0

CARD TYPE: XX XX - XX - X  
KEY ID

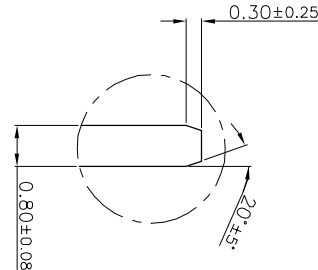
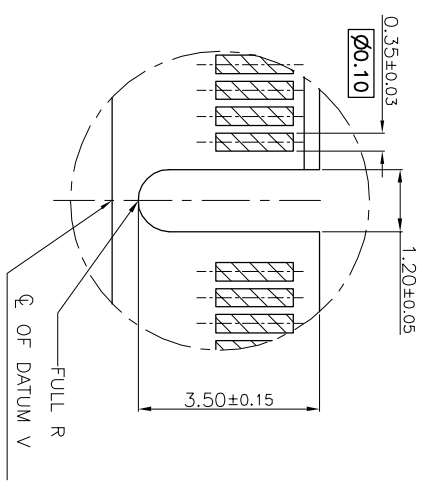

NO	DESCRIPTION	QTY	MATERIAL	PLATING & COLOR
UNLESS OTHERWISE SPECIFIED TOLERANCES				
DECIMALS: ANGLES:				
X	:±0.5	X	:±2°	
X.X	:±0.3	X.X	:±1°	
X.XX	:±0.2			
TITLE: NGFF MINI PCI CONNECTOR H=3.0mm(KEY A)				
DWN	ERIC	PART NO: 2NF3001-001111F		
CHKD	BOYE	SCALE:4:1 UNIT: mm		
APVD	LIAO	SIZE: A3 SHEET:3 OF 4 REV:B		

Singatron Enterprise Co., Ltd.  
信譽企業股份有限公司  
CUSTOMER COPY

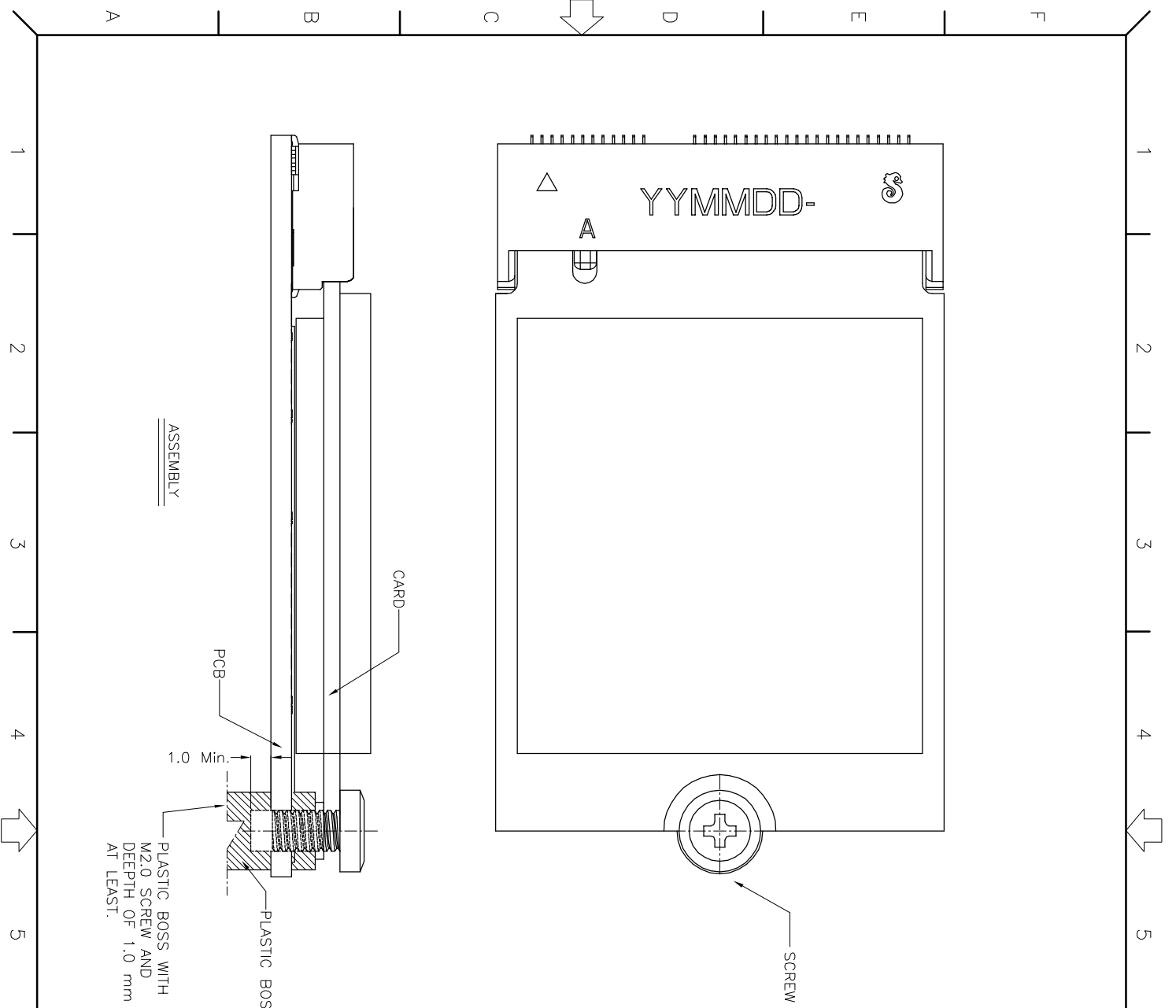

REV.	ECN NO OR DESCRIPTION	REVISED	DATE
A	PDR NO: T130807-3A	Dok	2014.06.04
B	ECN NO: S140674	ERIC	2014.10.22

TITLE	SCREW
MATERIAL	STAINLESS STEEL(SUS304)

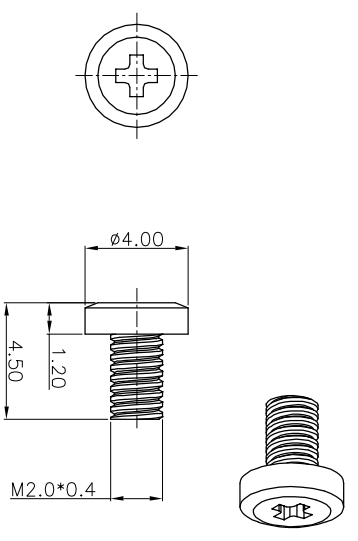

NO	DESCRIPTION	QTY	MATERIAL	PLATING & COLOR
UNLESS OTHERWISE SPECIFIED TOLERANCES				
DECIMALS: ANGLES:				
X	:±0.5	X	:±2°	
X.X	:±0.3	X.X	:±1°	
X.XX	:±0.2			
TITLE				
DWN	ERIC	PART NO: 2NFS001-001111F		
CHKD	BOYE	SCALE:4:1	UNIT: mm	
APVD	LIAO	SIZE: A3	SHEET: 4 OF 4	REV: B

ASSEMBLY

Singatron Enterprise Co., Ltd.  
信譽企業股份有限公司  
NGFF MINI PCI CONNECTOR  
H=3.0mm(KEY A)

CUSTOMER COPY