

| REV. | ECN NO OR DESCRIPTION | REVISED | DATE |
|------|-----------------------|---------|------------|
| A | PDR NO: T140326-3A | Ddk | 2014.06.04 |
| B | ECN NO: S151030-C | Charles | 2015.11.19 |

- SPECIFICATIONS:
1. ELECTRICAL CHARACTERISTICS:
- 1-1. CURRENT : 0.5A PER PIN.
 - 1-2. ILCR: INITIAL: 55 mΩ MAX;
FINAL: ΔILCR=20 mΩ MAX;
2. MECHANICAL CHARACTERISTICS:
- 2-1. TERMINAL'S RETENSION FORCE TO BE 0.2KG/PIN MIN.
3. DURABILITY: 25 CYCLES.
4. IR REFLOW:
- THE TEMPERATURE SHALL BE 260±5°C MAINTAINING 10±1 SECONDS.
5. TO CONFORM TO SINGATRON HAZARDOUS SUBSTANCE FREE SPEC.
6. HALOGEN PRODUCT IDENTIFICATION MARK ON JACK: ©
7. HALOGEN PRODUCT IDENTIFICATION LABEL ON PACKAGING: 
8. DATE : YYMMDD-
9. PACKAGING : TAPE & REEL

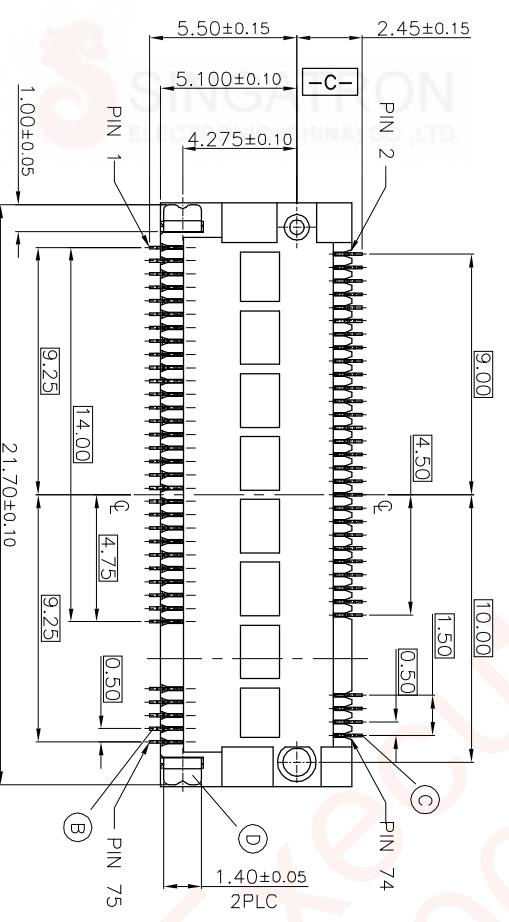
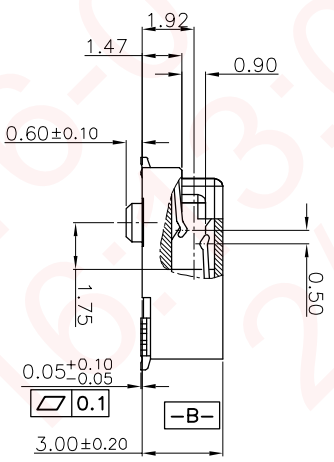
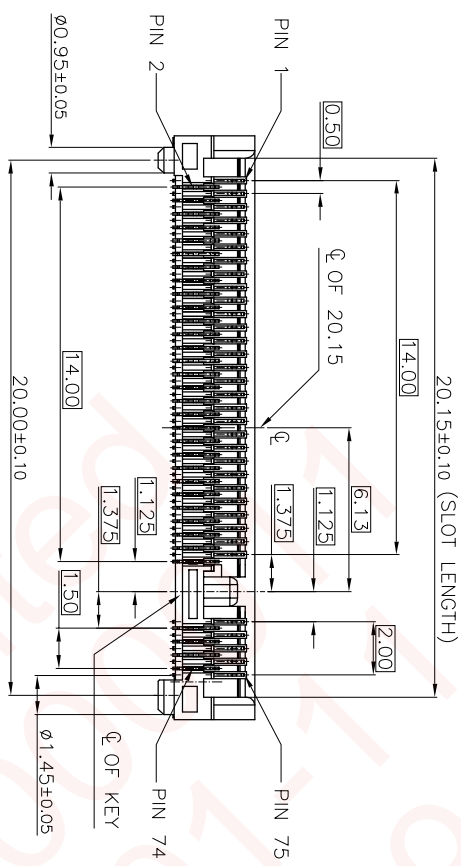
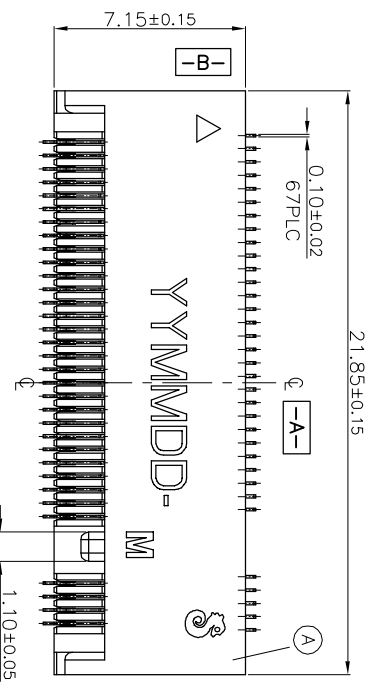

| NO | DESCRIPTION | QTY | MATERIAL | PLATING & COLOR |
|----|--------------|-----|-----------------------|---|
| D | FITTING NAIL | 2 | C2680-H, T=0.20 | Matl. Sn 100um PLATED ON ALL AREA; ALL OVER 50um NICKEL PLATING. |
| C | D-TERMINAL | 33 | C5210-EH, T=0.10/B | GOLD FLASH PLATED ON MATING AREA GOLD FLASH PLATED ON SOLDERING ALL OVER 50um NICKEL PLATING. |
| B | U-TERMINAL | 34 | C5210-EH, T=0.10/B | |
| A | BODY | 1 | LCP E6808 UHF Z+40%GF | BLACK |

| UNLESS OTHERWISE SPECIFIED TOLERANCES | | SINGATRON ENTERPRISE CO., LTD. | |
|---------------------------------------|-----------|---|--|
| DECIMALS: | ANGLES: |  Singatron Enterprise Co., Ltd. 信晋企业股份有限公司 NGFP MINI PCI CONNECTOR H=3.0mm(KEY M) | |
| X : ±0.5 | X : ±2° | | |
| X.X : ±0.3 | X.X : ±1' | | |
| X.XX : ±0.2 | | | |

| CUSTOMER COPY | | | |
|---------------|-------------------------|--------------------------|----------------------|
| TITLE | NGFP MINI PCI CONNECTOR | | |
| DWN | Charles | PART NO: 2NF3001-012111F | |
| CHKD | James | SCALE: 4:1 | UNIT: mm |
| APVD | BOYE | SIZE: A3 | SHEET: 1 OF 4 REV: B |

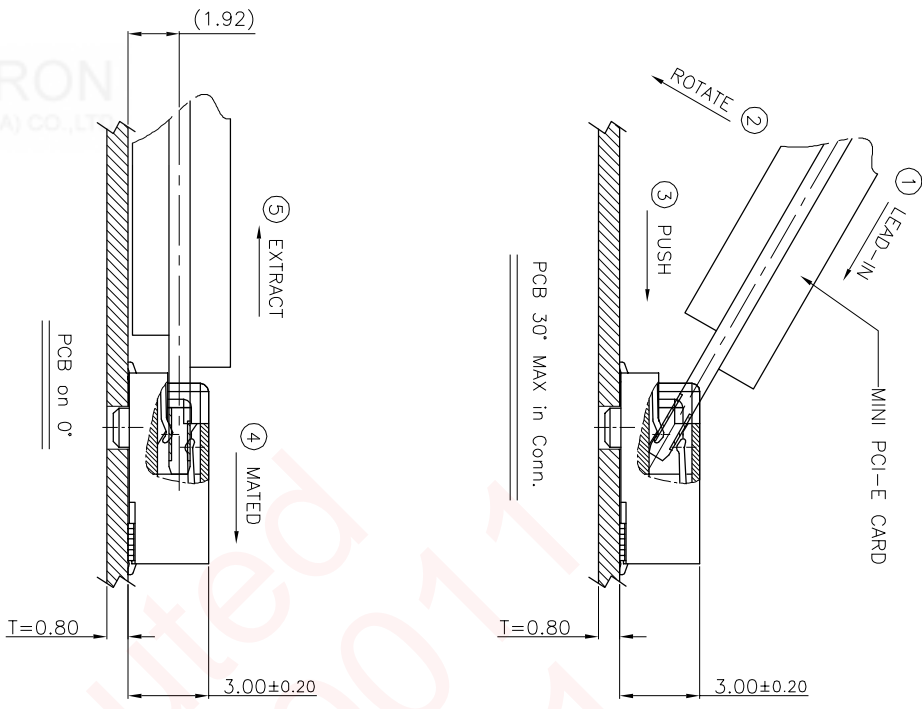
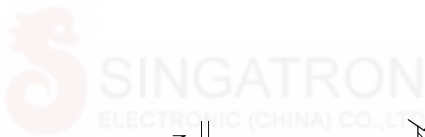

HOW TO MATE AND UNMATE
MATING FORCE WILL GENERATE FROM STEP 3 TO STEP 4

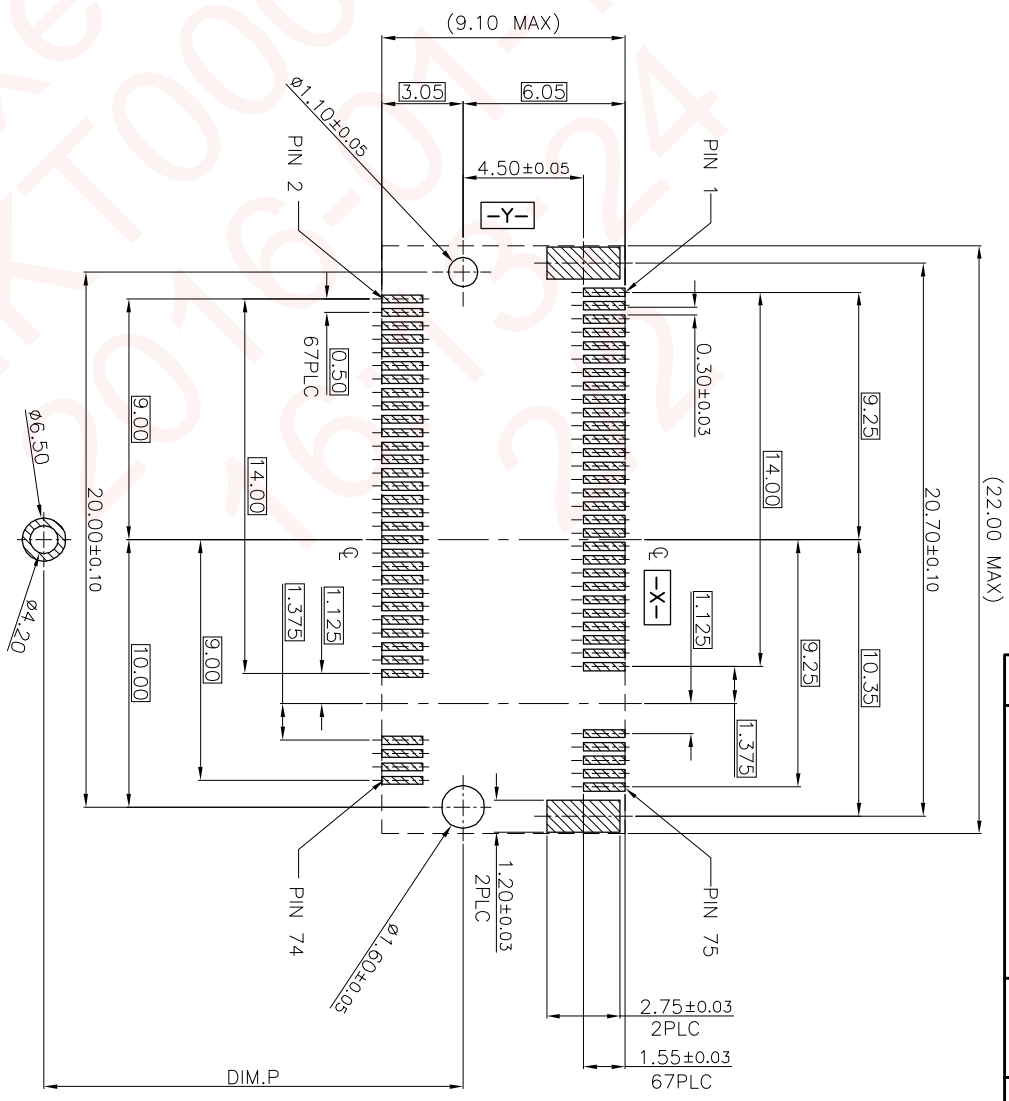

RECOMMENDED PCB LAYOUT(TOP VIEW)
DEFAULT TOLERANCE ±0.05MM

| NO | DESCRIPTION | QTY | MATERIAL | PLATING & COLOR |
|-------|-------------|-----|----------|-----------------|
| 22110 | 108.25 | | | |
| 2280 | 78.25 | | | |
| 2260 | 58.25 | | | |
| 2242 | 40.25 | | | |
| 2242 | 40.25 | | | |
| 3030 | 28.25 | | | |
| 2230 | 28.25 | | | |
| | | | | |

| NO | DESCRIPTION | QTY | MATERIAL | PLATING & COLOR |
|----|---------------------------------------|-----|----------|-----------------|
| | UNLESS OTHERWISE SPECIFIED TOLERANCES | | | |
| | DECIMALS: | | | |
| | ANGLES: | | | |
| | X : ±0.5 | | | |
| | X.X : ±0.3 | | | |
| | X.XX : ±0.2 | | | |
| | X.XX | | | |
| | | | | |

| TITLE | PART NO. | UNIT | REV. |
|-------------------------|-----------------|----------|--------------|
| NGFF MINI PCI CONNECTOR | 2NF3001-012111F | mm | |
| CHKD | SCALE:4:1 | mm | |
| APVD | BOYE | SIZE: A3 | SHEET:2 OF 4 |

CUSTOMER COPY

| REV. | ECN NO OR DESCRIPTION | REVISED | DATE |
|------|-----------------------|---------|------------|
| A | PDR NO: T140326-3A | Ddk | 2014.06.04 |
| B | ECN NO: S151030-C | Charles | 2015.11.19 |

| REV | ECN NO OR DESCRIPTION | REVISED | DATE |
|-----|-----------------------|---------|------------|
| A | PDR NO: T140326-3A | Dok | 2014.06.04 |
| B | ECN NO: S151030-C | Charles | 2015.11.19 |

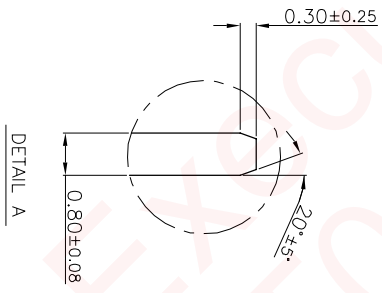
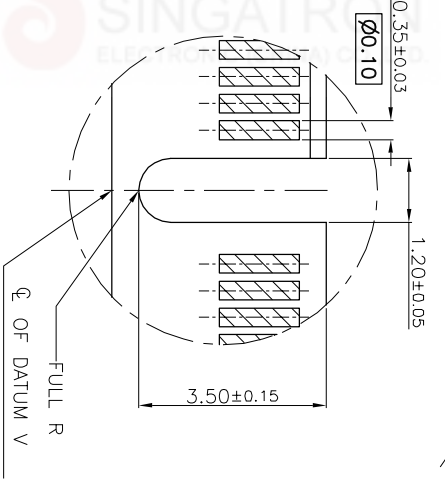
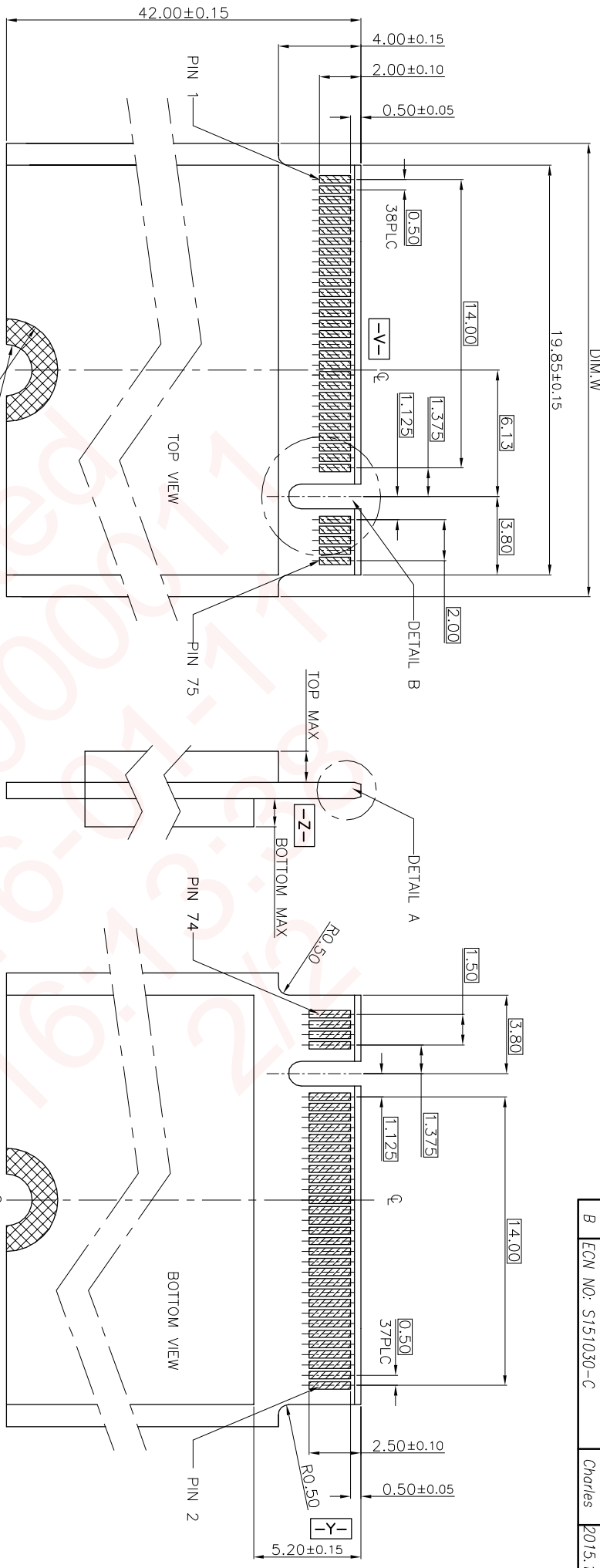

| Width (mm) | DIM W |
|------------|-------|
| 22 | 30 |

| Length (mm) | DIM L |
|-------------|-------|
| 30 | 42 |
| | 60 |
| | 80 |
| | 110 |

| Component | MAX H | |
|-----------|-------|--------|
| | Top | Bottom |
| D1 | 1.20 | 1.35 |
| D2 | 1.35 | 1.35 |
| D3 | 1.5 | 1.35 |
| D4 | 1.5 | 1.0 |

CARD TYPE: XX XX - XX - X

KEY ID

| NO | DESCRIPTION | QTY | MATERIAL | PLATING & COLOR |
|------|---------------------------------------|-----|----------|-----------------|
| | UNLESS OTHERWISE SPECIFIED TOLERANCES | | | |
| | DECIMALS: | | | |
| X | :±0.5 | X | :±2° | |
| X.X | :±0.3 | X.X | :±1° | |
| X.XX | :±0.2 | | | |

| TITLE | NGFP MINI Pci CONNECTOR |
|--------------------------|-------------------------|
| DWN | Charles |
| CHKD | James |
| APVD | BOYE |
| PART NO: 2NF3001-012111F | |
| SCALE: 4:1 | |
| UNIT: mm | |
| SIZE: A3 | |
| SHEET: 3 OF 4 | |
| REV: B | |

CUSTOMER COPY



Singatron Enterprise Co., Ltd.
信音企業股份有限公司

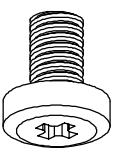
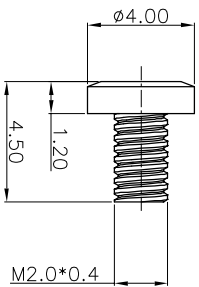
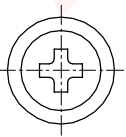
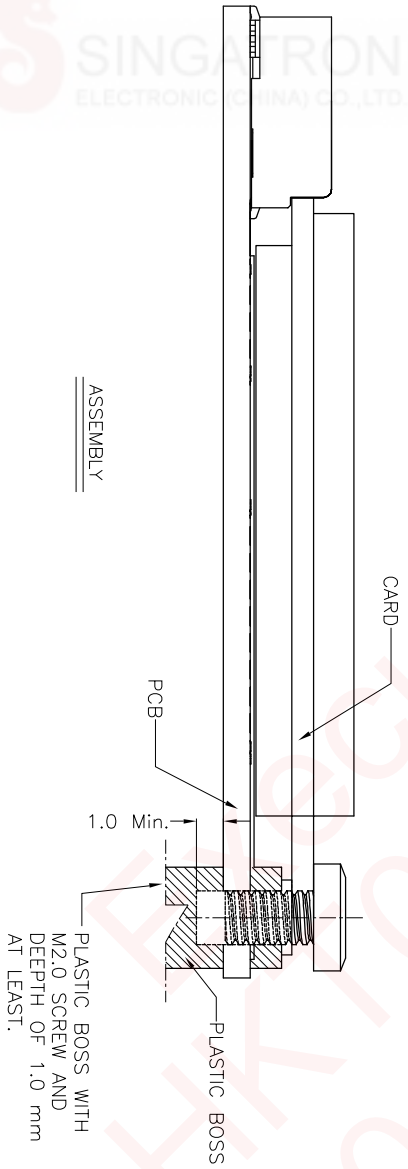
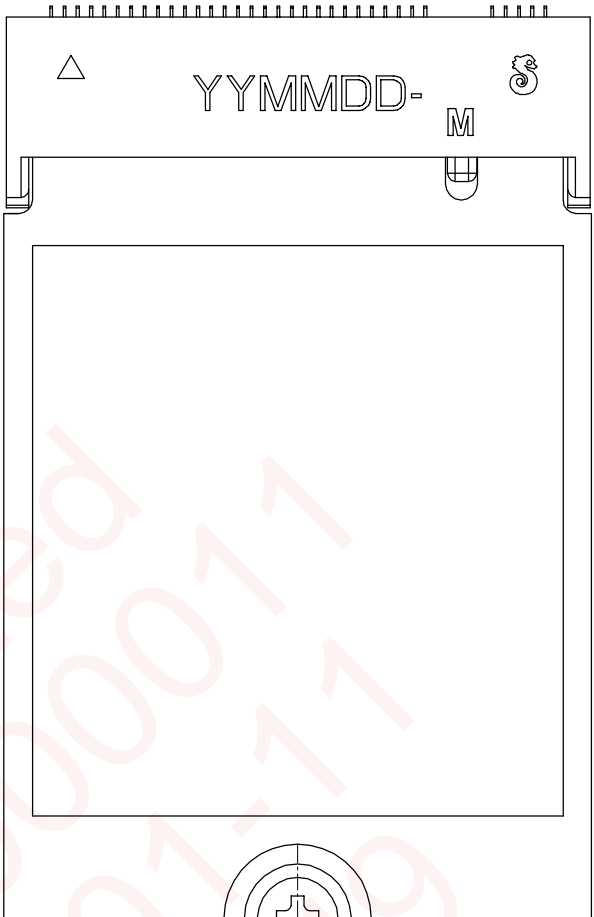
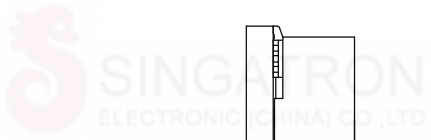

| REV. | ECN NO | OR DESCRIPTION | REVISED | DATE |
|------|--------------------|----------------|---------|------------|
| A | PDR NO: T140326-3A | | Dak | 2014.06.04 |
| B | ECN NO: S151030-C | | Charles | 2015.11.19 |

| | |
|----------|-------------------------|
| TITLE | SCREW |
| MATERIAL | STAINLESS STEEL(SUS304) |

| NO | DESCRIPTION | QTY | MATERIAL | PLATING & COLOR |
|---|-------------|-----|----------|-----------------|
| UNLESS OTHERWISE SPECIFIED TOLERANCES | | | | |
| DECIMALS: ANGLES: | | | | |
| X | :±0.5 | X | :±2° | |
| X.X | :±0.3 | X.X | :±1° | |
| X.XX | :±0.2 | | | |
| TITLE: NGFF MINI PCI CONNECTOR H=3.0mm(KEY M) | | | | |
| DWN: Charles | | | | |
| CHKD: James | | | | |
| APVD: BOYE | | | | |
| PART NO: 2NFF3001-012111F | | | | |
| SCALE: 4:1 | | | | |
| UNIT: mm | | | | |
| SIZE: A3 | | | | |
| SHEET: 4 OF 4 | | | | |
| REV: B | | | | |

CUSTOMER COPY