

REV.	ECN NO OR DESCRIPTION	REVISED	DATE
A	PDR RELEASE	IVY-C	2014.11.03

SPECIFICATIONS:

- ELECTRICAL CHARACTERISTICS:
 - CURRENT RATING: 0.5A(Per pin).
 - VOLTAGE RATING: 50V AC(Per pin).
 - LLCR: 55mΩ Max,(Initial), 20mΩ Max. change allowed(Final)
 - INSULATION RESISTANCE: 500MΩ MIN. @ 500V DC.
 - DIELECTRIC WITHSTANDING VOLTAGE: 300V AC FOR 1 MINUTE.
- MECHANICAL CHARACTERISTICS:
 - INSERTION FORCE: 20N MAX.
 - WITHDRAWAL FORCE: 20N MAX.
- LIFE TEST: 60 CYCLES.
- OTHER GENERAL SPEC. TO REFER "2NF3006 SERIES SPEC".
- TO CONFORM TO THE SINGATRON HAZARDOUS SUBSTANCE FREE SPEC.
- HALOGEN FREE PRODUCT IDENTIFICATION LABEL ON PACKAGING:
- PACKAGE: SEE "2NF3006 SERIES" PACKAGE.
- FOR REFLOW SOLDERING LEAD-FREE PROCESS.



PART NO.

2NF3006-000211F

- SUFFIX: HALOGEN FREE
- PACKAGE
- 1: TAPE AND REEL
- HOUSING COLOR
- 1: BLACK
- CONTACT PLATING
- 2: GOLD FLASH ON CONTACT AREA,
GOLD FLASH ON SOLDER AREA (BOTH SIDE)
NICKEL UNDERPLATED OVERALL.

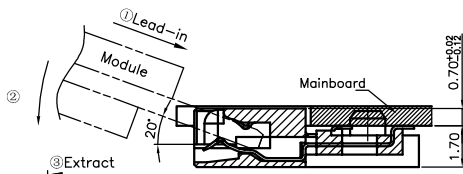
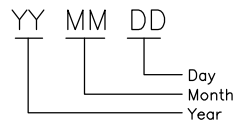
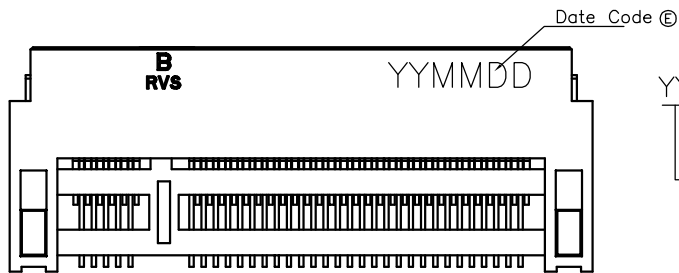
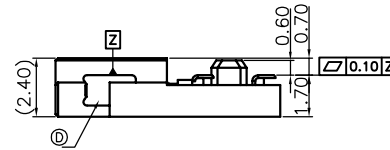
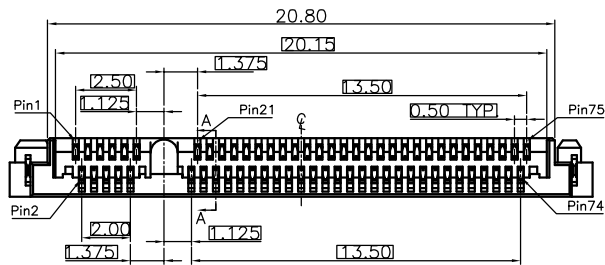
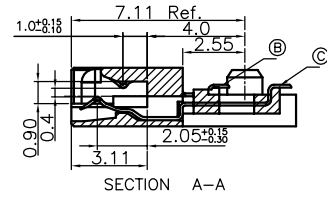
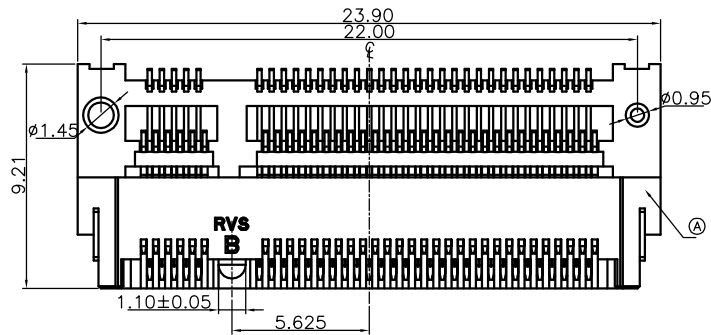

How to mate and unmate
Mate: ①-②
Unmate: ③

E	INK			BLACK
D	LEG	2	BRASS	G/F at solder area, all over nickel
C	Upper CONTACT	33	COPPER ALLOY	SEE PART NO.
B	Lower CONTACT	34	COPPER ALLOY	SEE PART NO.
A	HOUSING	1	HIGH TEMP. THERMOPLASTIC UL 94V-0	BLACK
NO	DESCRIPTION	QTY	MATERIAL	PLATING & COLOR
UNLESS OTHERWISE SPECIFIED TOLERANCES			Singatron Enterprise Co., Ltd. 信音企業股份有限公司	
DECIMALS:	ANGLES:	TITLE	NGFF Socket(M.2 Connector)Mid-plane,1.8H,RVS B Key	
X :±0.5	X :±2°	DWN	WY-C 2014.11.03	PART NO. 2NF3006-000211F
X.X :±0.3	X.X :±1°	CHKD		SCALE 1:1 UNIT: mm
X.XX :±0.2		APVD	ANGELA 2014.11.03	SIZE: A3 SHEET:1 OF 2 REV: A
CUSTOMER COPY				

REV.	ECN NO OR DESCRIPTION	REVISED	DATE
A	PDR RELEASE	IVY-C	2014.11.03

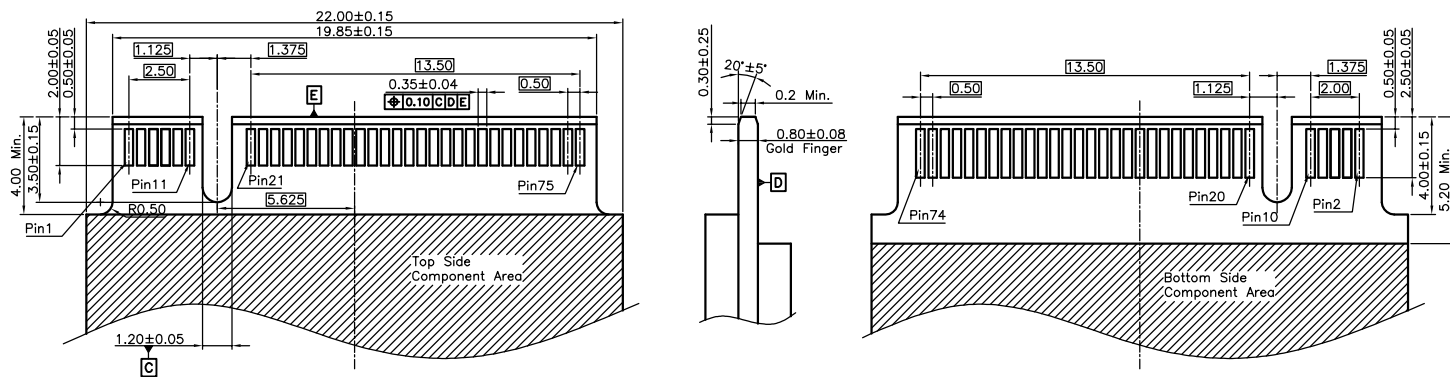

Recommended Mould Finger Layout

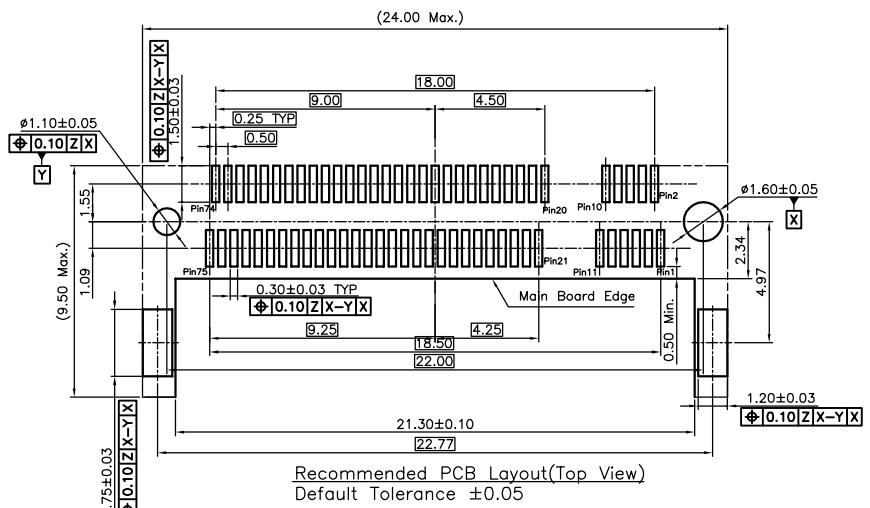

Recommended PCB Layout (Top View)
Default Tolerance ±0.05

NO	DESCRIPTION	QTY	MATERIAL	PLATING & COLOR
UNLESS OTHERWISE SPECIFIED TOLERANCES		Singatron Enterprise Co., Ltd. 信音企業股份有限公司		
DECIMALS:	ANGLES:	TITLE	NGFF Socket(M.2 Connector)Mid-plane,1.8H,RVS B Key	
X : ±0.5	X : ±2°	DWN	IVY-C 2014.11.03	PART NO. 2NF3006-000211F
XX : ±0.3	XX : ±1°	CHKD	SCALE 1:1	UNIT: mm
XX.XX : ±0.2		APVD	ANGELA 2014.11.03	SIZE: A3 SHEET: 2 OF 2
REV: A				
CUSTOMER COPY				