

REV.	EGN NO	OR DESCRIPTION	REVISED	DATE
A	PDR NO.:S140110-5B		Harlen	2014.11.27

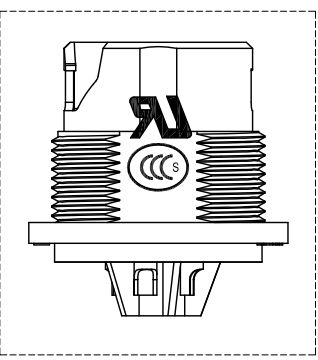

CUSTOMER P/N	SINGATRON P/N
EC09H100610401	2QM3014-W05301H

- NOTES:
1. ELECTRICAL CHARACTERISTICS:
- 1-1 CURRENT RATING: 6 AMPS.
 - 1-2 CONTACT RESISTANCE: 30 mOhm Max.
 - 1-3 INSULATION RESISTANCE: 100 MOhm Min. at 500VDC.
 - 1-4 BREAKDOWN VOLTAGE: 500 VAC PER MINUTE.
2. MECHANICAL CHARACTERISTICS:
- 2-1 TIGHTENING TORQUES: 0.8~1.0Nm(7.08~8.85lbf.in.).
 - 2-2 CONTACT ACCOMMODATION: 18~24 AWG.
3. ENVIRONMENTAL:
- 3-1 OPERATING TEMPERATURE: -40°C TO +105°C.
 - 3-2 SEALING REQUIREMENTS: IP67.
4. LIFE TEST: 1,000 CYCLES MIN.
5. FOR PANEL THICKNESS MAX OF 3.5mm
6. OTHER GENERAL SPEC. TO REFER "QUICK SERIES GENERAL SPEC".
7. FOR TECHNICAL DATA REFER TO YOUR LOCAL SINGATRON ELECTRONICS SALES OFFICE.
8. ALL DIMENSIONS ARE NOMINAL FOR REFERENCE ONLY UNLESS OTHERWISE STATED.
9. TO CONFORM TO SINGATRON HAZARDOUS SUBSTANCE FREE SPEC.
10. GREEN PRODUCT IDENTIFICATION LABEL ON PACKAGING **GREEN PASS**

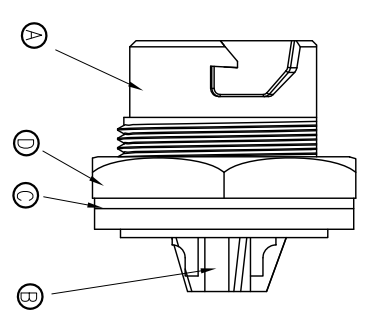
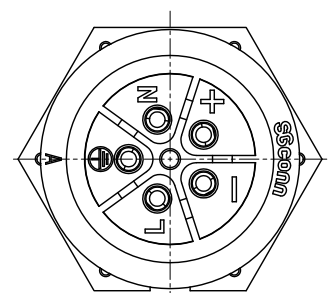
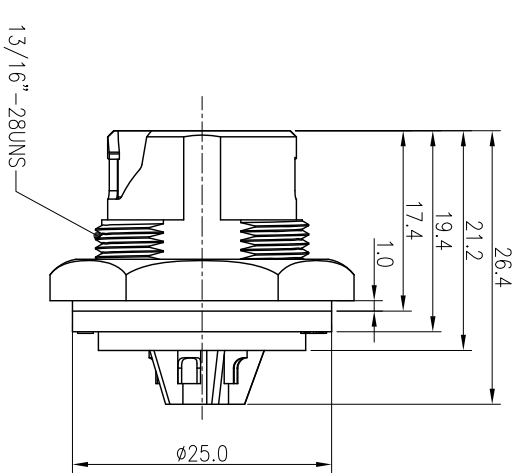
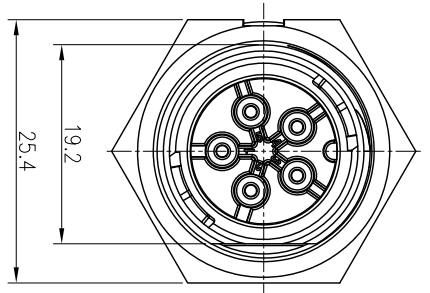
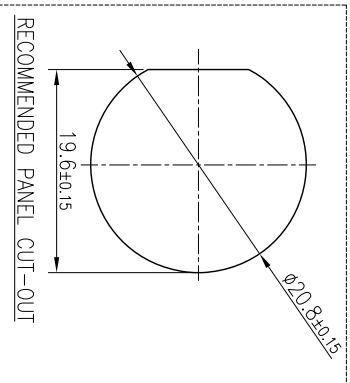

NO	DESCRIPTION	QTY	MATERIAL	PLATING & COLOR
D	NIUT	1	PA66	GRAY
C	GASKET	1	SILICONE	BLACK
B	FEMALE PIN	5	COPPER ALLOY	1~3μ" GOLD PLATING OVER NICKEL PLATING
A	BODY	1	PA66	GRAY

UNLESS OTHERWISE SPECIFIED TOLERANCES

DECIMALS: ANGLES:

X : ±0.5 X : ±2°

X.X : ±0.3 X.X : ±1°

X.XX : ±0.2

Singatron Enterprise Co., Ltd.
信善企業股份有限公司

CIRCULAR SERIES QUICK TYPE MIDDLE SIZE
MALE CONN. FEMALE 5 PIN

Part No. 2QM3014-W05301H

Harlen

Scale 2:1

Unit: mm

APVD STEVE

Size: A3

Sheet: 1 of 1

REV: A

CUSTOMER COPY