

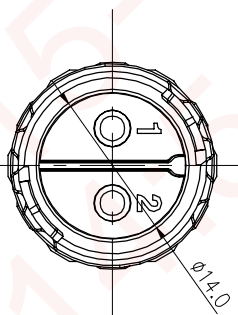

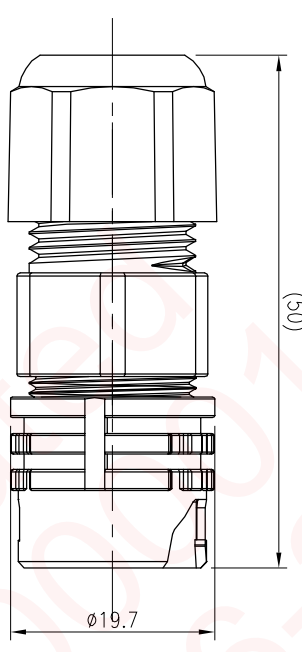

REV.	ECN NO OR DESCRIPTION	REVISED	DATE
A	PDR NO.:S140227-5G	Horlen	2015.1.20
B	ECN NO.:S150627-R/A	Vicky	2015.06.11

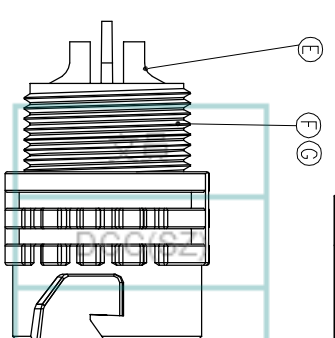

- NOTES:
- ELECTRICAL CHARACTERISTICS:
    - 1-1 CURRENT RATING: 20 AMPS.
    - 1-2 CONTACT RESISTANCE: 30 mOhm Max.
    - 1-3 INSULATION RESISTANCE: 100 MOhm Min. at 500VDC.
    - 1-4 BREAKDOWN VOLTAGE: 1000 VAC PER MINUTE.
  - MECHANICAL CHARACTERISTICS:
    - 2-1 TIGHTENING TORQUES: 1.0~1.2Nm(8.85~10.62lbf.in.).
    - 2-2 CONTACT ACCOMMODATION:14~20 AWG.
  - ENVIRONMENTAL:
    - 3-1 OPERATING TEMPERATURE: -40°C TO +105°C.
    - 3-2 SEALING REQUIREMENTS: IP67.
    - 3-3 SEAL FOR CABLE OD: <math>\phi 7.0\text{mm}</math>~<math>\phi 10.0\text{mm}</math>.
  - LIFE TEST: 1,000 CYCLES MIN.
  - OTHER GENERAL SPEC TO REFER "QUICK SERIES GENERAL SPEC".
  - FOR TECHNICAL DATA REFER TO YOUR LOCAL SINGATRON ELECTRONICS SALES OFFICE.
  - ALL DIMENSIONS ARE NOMINAL FOR REFERENCE ONLY UNLESS OTHERWISE STATED.
  - TO CONFORM TO SINGATRON HAZARDOUS SUBSTANCE FREE SPEC.
  - GREEN PRODUCT IDENTIFICATION LABEL ON PACKAGING 

G	BODY	1	PA66	BLACK
F	LIQUID GLUE	1	N/A	BLACK
E	MALE PIN	2	BRASS	1~3u" GOLD PLATING OVER NICKEL PLATING
D	GASKET	1	SILICONE	BLACK
C	CLAMP RING	1	PC	BLACK
B	SEAL	1	EPDM	BLACK
A	SEALING NUT	1	PA66	BLACK
NO	DESCRIPTION	QTY	MATERIAL	PLATING & COLOR
UNLESS OTHERWISE SPECIFIED TOLERANCES				
 Singatron Enterprise Co., Ltd. 信亨企業股份有限公司				
CIRCULAR SERIES QUICK TYPE MIDDLE SIZE				
TITLE MALE CONN. MALE 2 PIN				
DMN	Vicky	PART NO.2QM3033-W02600H		
CHKD	Harlen	SCALE 2:1	UNIT: mm	
APVD	Steve	SIZE: A3	SHEET: 1 OF 1	REV: B

CUSTOMER COPY