

REV.	ECN NO.	OR DESCRIPTION	REVISED	DATE
A	PDR NO.:S140114-2D	Horlen	2014.11.27	
B	ECN NO.:S150343-C	Susie	2015.03.20	

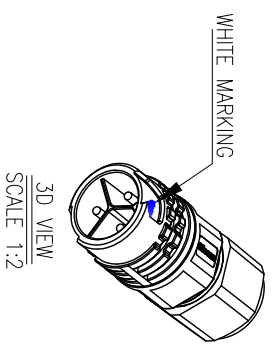
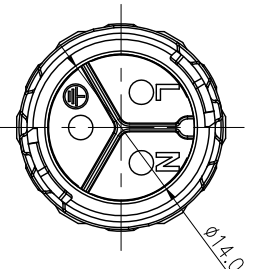
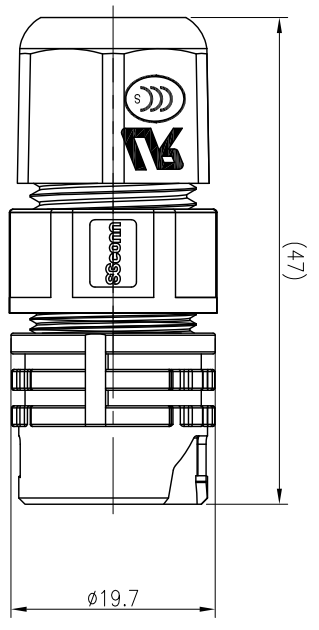
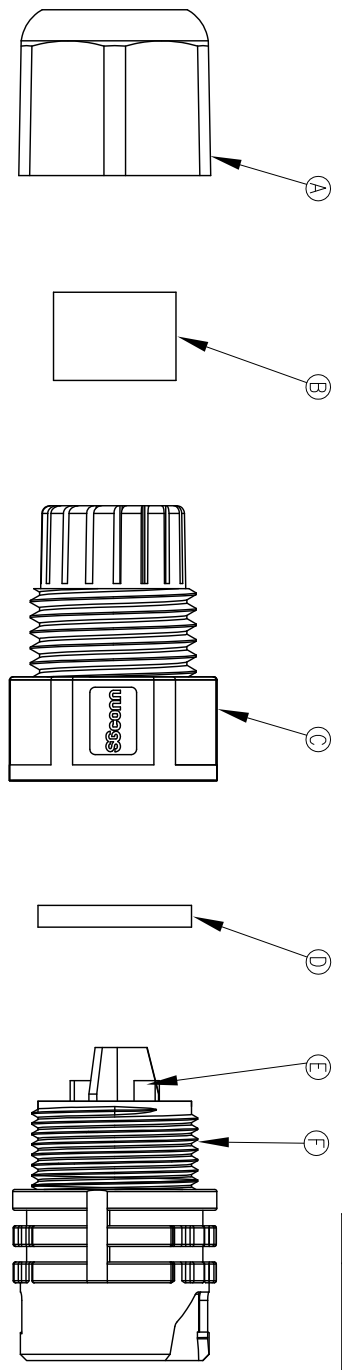

- NOTES:
1. ELECTRICAL CHARACTERISTICS:
- 1-1 CURRENT RATING: 10 AMPS.
 - 1-2 CONTACT RESISTANCE: 30 mOhm Max.
 - 1-3 INSULATION RESISTANCE: 100 Mohm Min. at 500VDC.
 - 1-4 BREAKDOWN VOLTAGE: 1000 VAC PER MINUTE.
2. MECHANICAL CHARACTERISTICS:
- 2-1 TIGHTENING TORQUES: 1.0~1.2Nm(8.85~10.62lb·in.).
 - 2-2 CONTACT ACCOMMODATION: 18~20 AWG.
3. ENVIRONMENTAL:
- 3-1 OPERATING TEMPERATURE: -40°C TO +105°C.
 - 3-2 SEALING REQUIREMENTS: IP67.
4. SEAL FOR CABLE OD: $\phi 6.0\text{mm} \sim \phi 9.0\text{mm}$.
5. LIFE TEST: 1,000 CYCLES MIN.
6. OTHER GENERAL SPEC TO REFER "QUICK SERIES GENERAL SPEC."
7. FOR TECHNICAL DATA REFER TO YOUR LOCAL SINGATRON ELECTRONICS SALES OFFICE.
8. ALL DIMENSIONS ARE NOMINAL FOR REFERENCE ONLY UNLESS OTHERWISE STATED.
9. TO CONFORM TO SINGATRON HAZARDOUS SUBSTANCE FREE SPEC.
10. GREEN PRODUCT IDENTIFICATION LABEL ON PACKAGING:

F	BODY	1	PA66	GRAY(PANTONG 427C)
E	MALE PIN	3	BRASS	1~3u" GOLD PLATING OVER NICKEL PLATING
D	GASKET	1	SILICONE	BLACK
C	CLAMP RING	1	PC	GRAY(PANTONG 427C)
B	SEAL	1	SILICONE	BLACK
A	SEALING NUT	1	PC	GRAY(PANTONG 427C)
NO	DESCRIPTION	QTY	MATERIAL	PLATING & COLOR
UNLESS OTHERWISE SPECIFIED TOLERANCES				
Singatron Enterprise Co., Ltd. 信善企業股份有限公司				
CIRCULAR SERIES MIDDLE SIZE (SOLDER TYPE)				
TITLE: MALE CONN. MALE 3 PIN				
DECIMALS:	ANGLES:			
X : ±0.5	X : ±2°			
X.X : ±0.3	X.X : ±1°			
X.XX : ±0.2				
APVD Stave SIZE: A3 SHEET: 1 OF 1 REV: B				
CUSTOMER COPY				