

REV	ECN NO	OR DESCRIPTION	REVISED	DATE
A	PDR NO.:S141223-6Z	Horlen	2015.1.9	

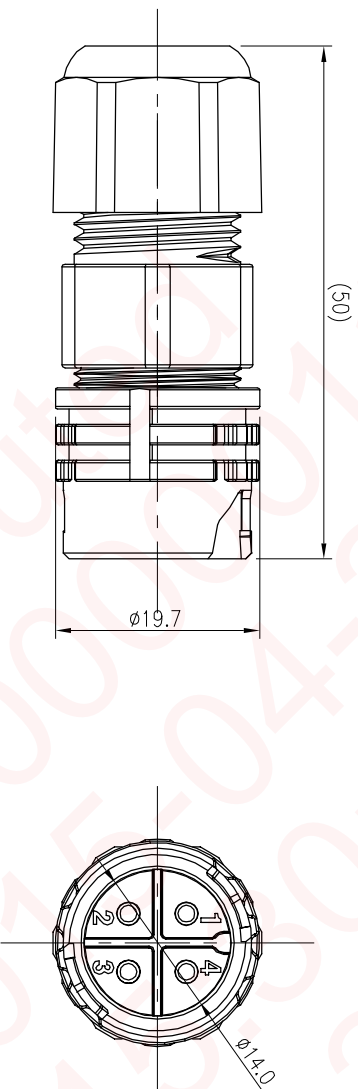
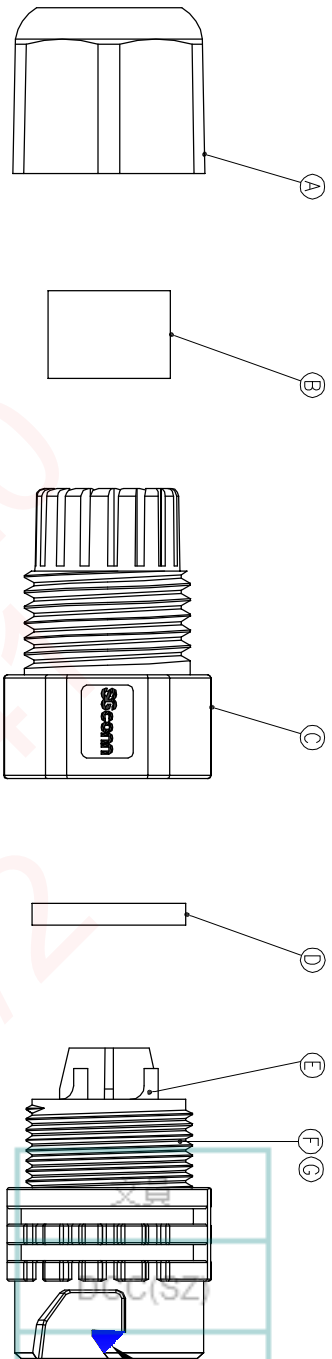

NOTES:

1. ELECTRICAL CHARACTERISTICS:

- 1-1 CURRENT RATING: 10 AMPS.
- 1-2 CONTACT RESISTANCE: 30 mΩhm Max.
- 1-3 INSULATION RESISTANCE: 100 MΩhm Min. at 500VDC.
- 1-4 BREAKDOWN VOLTAGE: 1000 VAC PER MINUTE.

2. MECHANICAL CHARACTERISTICS:

- 2-1 TIGHTENING TORQUES: 1.0~1.2Nm(8.85~10.62lbf.in.).
- 2-2 CONTACT ACCOMMODATION:16~20 AWG.

3. ENVIRONMENTAL:

- 3-1 OPERATING TEMPERATURE: -40°C TO +105°C.
- 3-2 SEALING REQUIREMENTS: IP67.
- 3-3 SEAL FOR CABLE OD: $\phi 7.0\text{mm}$~$\phi 10.0\text{mm}$.

4. LIFE TEST: 1,000 CYCLES MIN.

5. OTHER GENERAL SPEC TO REFER "QUICK SERIES GENERAL SPEC".

6. FOR TECHNICAL DATA REFER TO YOUR LOCAL SINGATRON ELECTRONICS SALES OFFICE.

7. ALL DIMENSIONS ARE NOMINAL FOR REFERENCE ONLY UNLESS OTHERWISE STATED.

8. TO CONFORM TO SINGATRON HAZARDOUS SUBSTANCE FREE SPEC.

9. GREEN PRODUCT IDENTIFICATION LABEL ON PACKAGING **RoHS PASS**

G	BODY	1	PA66	BLACK
F	LIQUID GLUE	1	N/A	BLACK
E	MALE PIN	3	COPPER ALLOY	1~3μ" GOLD PLATING OVER NICKEL PLATING
D	GASKET	1	SILICONE	BLACK
C	CLAMP RING	1	PC	BLACK
B	SEAL	1	SILICONE	BLACK
A	SEALING NUT	1	PA66	BLACK
NO	DESCRIPTION	QTY	MATERIAL	PLATING & COLOR
UNLESS OTHERWISE SPECIFIED TOLERANCES				
Singatron Enterprise Co., Ltd. 信亨企業股份有限公司				
TITLE CIRCULAR SERIES QUICK TYPE MIDDLE SIZE MALE CONN. MALE 3 PIN				
DECIMALS:		ANGLES:		
X	:±0.5	X	:±2°	
X.X	:±0.3	X.X	:±1°	
X.XX	:±0.2			

CUSTOMER COPY