

REV.	ECN NO OR DESCRIPTION	REVISED	DATE
A	PDR NO.:S140605-2B	Harlen	2014.11.28
B	ECN NO.:S150367-R	Blues	2015.03.31
C	ECN NO.:S150417-R	Blues	2015.04.13

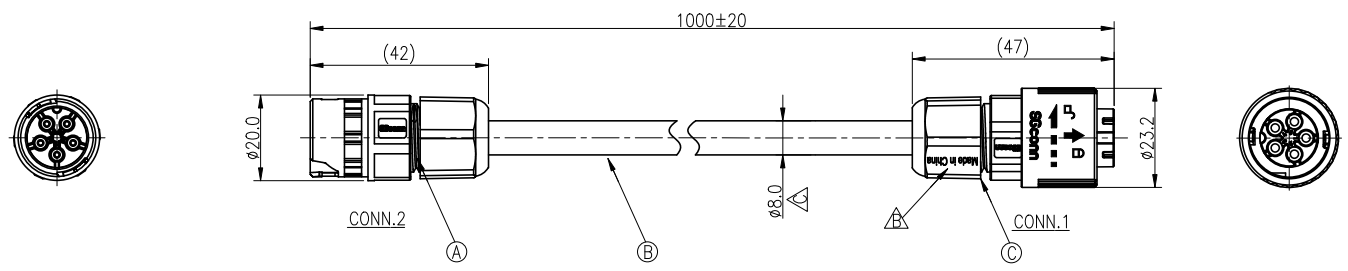

CONN.1	WIRE COLOR	CONN.2	
5	L BROWN	5	L
4	- BLACK	4	-
3	+ GRAY	3	+
2	N BLUE	2	N
1	● YELLOW/GREEN	1	●

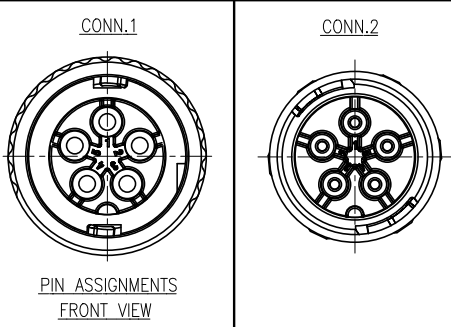

- NOTES:
- ELECTRICAL CHARACTERISTICS:
    - 1-1 CURRENT RATING: 6 AMPS.
    - 1-2 CONTACT RESISTANCE: 100 mOhm Max.(INCLUDED CABLE'S RESISTANCE).
    - 1-3 INSULATION RESISTANCE: 100 MOhm Min. at 500VDC.
    - 1-4 BREAKDOWN VOLTAGE: 500 VAC PER MINUTE.
  - ENVIRONMENTAL:
    - 2-1 OPERATING TEMPERATURE: -20°C TO +80°C.
    - 2-2 SEALING REQUIREMENTS: N/A.
  - LIFE TEST: 1,000 CYCLES MIN.
  - OTHER GENERAL SPEC. TO REFER "QUICK SERIES GENERAL SPEC"
  - FOR TECHNICAL DATA REFER TO YOUR LOCAL SINGATRON ELECTRONICS SALES OFFICE.
  - ALL DIMENSIONS ARE NOMINAL FOR REFERENCE ONLY UNLESS OTHERWISE STATED.
  - TO CONFORM TO SINGATRON HAZARDOUS SUBSTANCE FREE SPEC.
  - GREEN PRODUCT IDENTIFICATION LABEL ON PACKAGING:

		CUSTOMER P/N	SINGATRON P/N	
		MHCAH100611400	2QM3036-W05303H	
C	2QM3037-W05301H	1	MALE CONN. FEMALE 5 PIN(6A)	GRAY(PANTONG 427C)
B	CABLE	1	H05W-F 5G0.75mm <sup>2</sup>	GRAY(PANTONG 427C)
A	2QM3036-W05301H	1	FEMALE CONN. MALE 5 PIN(6A)	GRAY(PANTONG 427C)
NO	DESCRIPTION	QTY	MATERIAL	PLATING & COLOR
UNLESS OTHERWISE SPECIFIED TOLERANCES		Singatron Enterprise Co., Ltd. 信音企業股份有限公司		
DECIMALS: ANGLES:		TITLE QUICK SERIES MIDDLE SIZE FEMALE CONN. TO MALE CONN.		
X	:±0.5	X	:±2'	DWN Blues PART NO.2QM3036-W05303H
X.X	:±0.3	X.X	:±1'	CHKD Harlen SCALE 1:1 UNIT: mm
X.XX	:±0.2			APVD Steve SIZE: A3 SHEET:1 OF 1 REV: C
CUSTOMER COPY				