

REV.	ECN NO	OR DESCRIPTION	REVISED	DATE
A	PDR NO.: A171207-7A		JF	2018.04.09

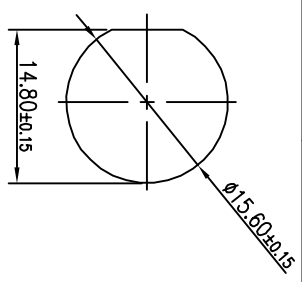

RECOMMENDED PANEL CUT-OUT

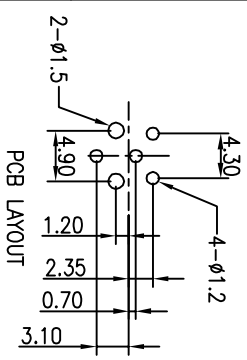
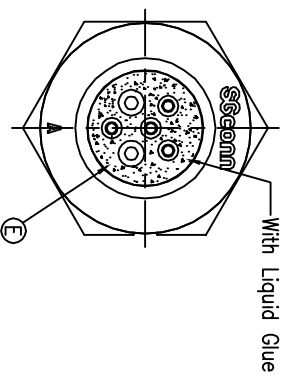
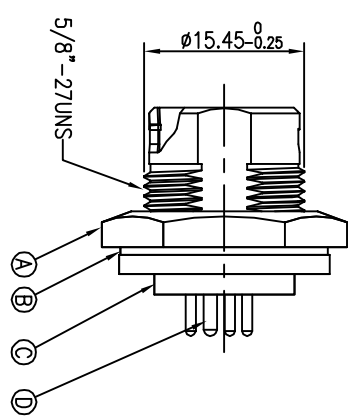
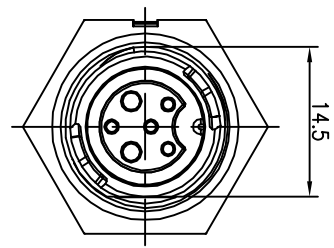
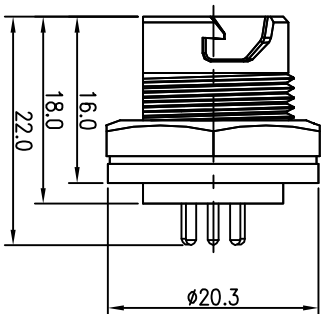

PCB LAYOUT

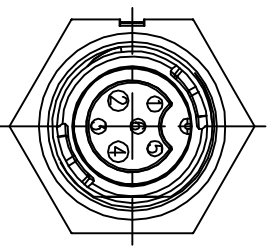

PIN ASSIGNMENTS  
FRONT VIEW

- NOTES:
- ELECTRICAL CHARACTERISTICS:
    - 1-1 CURRENT RATING: 10+5 AMPS.
    - 1-2 CONTACT RESISTANCE: 30 mOhm Max.
    - 1-3 INSULATION RESISTANCE: 100 Mohm Min at 500VDC.
    - 1-4 BREAKDOWN VOLTAGE: 500 VAC PER MINUTE.
  - MECHANICAL CHARACTERISTICS:
    - 2-1 TIGHTENING TORQUES: 0.8~1.0Nm(7.08~8.85lbf.in.).
  - ENVIRONMENTAL:
    - 3-1 OPERATING TEMPERATURE: -40°C TO +105°C.
    - 3-2 SEALING REQUIREMENTS: IP67.
    - 4. LIFE TEST: 1,000 CYCLES MIN.
    - 5. FOR PANEL THICKNESS MAX OF 4.0mm
  - OTHER GENERAL SPEC TO REFER CIRCULAR SERIES GENERAL SPEC\*.
  - FOR TECHNICAL DATA REFER TO YOUR LOCAL SINGATRON ELECTRONICS SALES OFFICE.
  - ALL DIMENSIONS ARE NOMINAL FOR REFERENCE ONLY UNLESS OTHERWISE STATED.
  - TO CONFORM TO SINGATRON HAZARDOUS SUBSTANCE FREE SPEC.
  - GREEN PRODUCT IDENTIFICATION LABEL ON PACKAGING: [See Page 1](#).

E	LIQUID GLUE	1	N/A	BLACK
D	FEMALE PIN	6	Phosphor Bronze	1~3μ" GOLD PLATING OVER NICKEL PLATING
C	BODY	1	PA66	BLACK
B	GASKET	1	EPDM	BLACK
A	NUT	1	PA66	BLACK
NO	DESCRIPTION	QTY	MATERIAL	PLATING & COLOR
UNLESS OTHERWISE SPECIFIED TOLERANCES				
Singatron Enterprise Co., Ltd. 信譽企業股份有限公司				
TITLE CIRCULAR STANDARD SIZE (QUICK TYPE)				
DWN JF MALE CONN. FEMALE (2+4) PIN (10+5)A				
CHKD Jun PART NO. 2QT3012-W06800H				
APVD Steve SIZE: A3 SHEET: 1 OF 1 REV: A				
CUSTOMER COPY				

DECIMALS:	ANGLES:
X :±0.5	X :±2°
X.X :±0.3	X.X :±1°
X.XX :±0.2	