

REV/ECN NO	OR DESCRIPTION	REVISED	DATE
A	PDR NO:1T20306-5A	Soldier	2012.05.14

PART NO.:
2RF1010-015013F

NO.:	STATEMENT
0	Hold Back
1	STRAIGHT 75ohm
5	ASSEMBLY FOR CABLE+PANEL
0	JACK
13	SERIES NO.
F	HALOGEN FREE

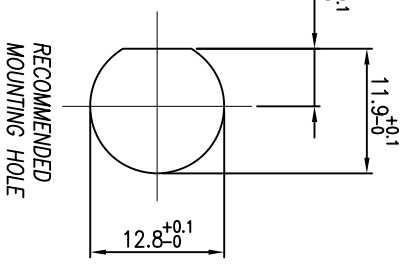
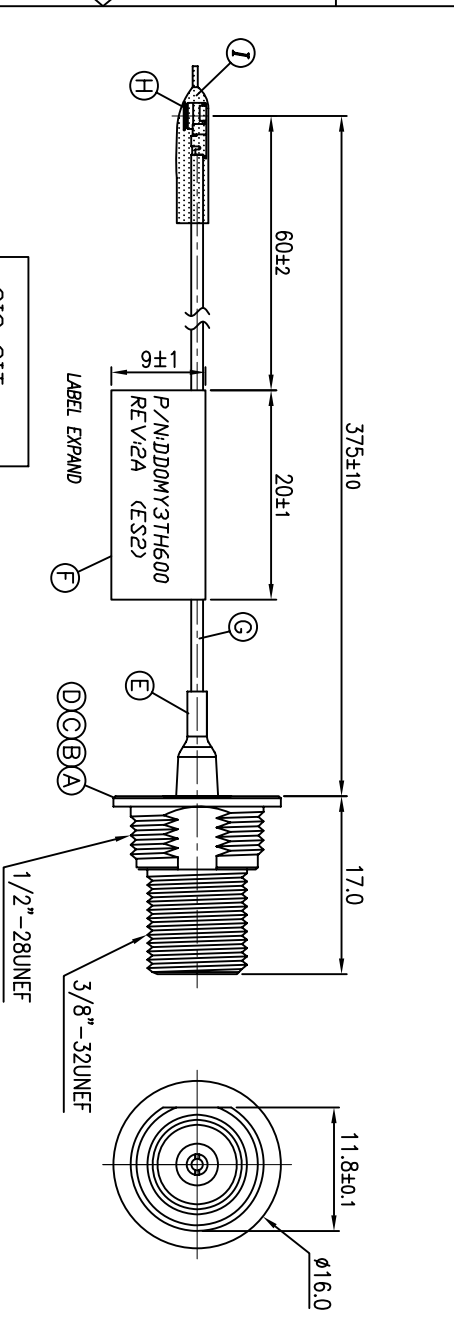
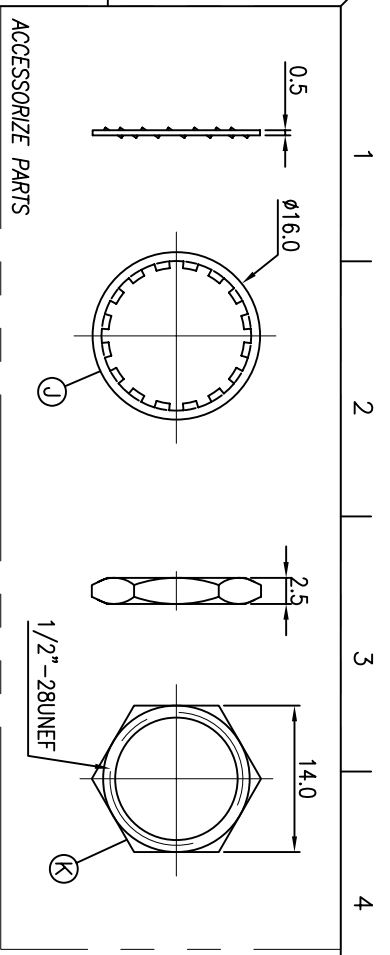

SIG-SIT
YYMMDD
P/N:DDDMY3TH600
REV:1/2A (ES2)

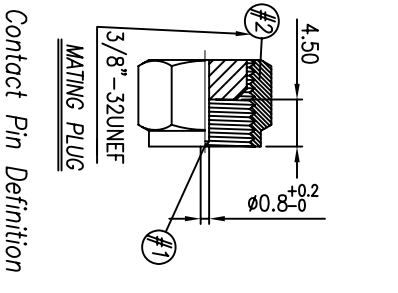
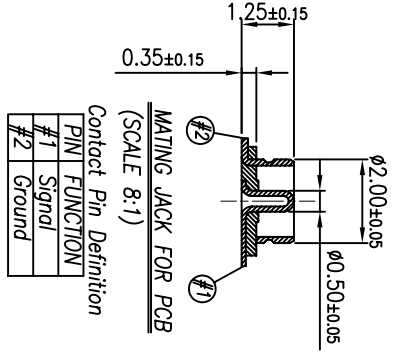

- SPECIFICATIONS:**
1. IMPEDANCE : 75ohm for NTSC NOMINAL
 2. FREQUENCY RANGE : 0~2 GHz
 3. INSERTION LOSS : 1.5 dB AT 1 GHz
 4. OTHER GENERAL SPEC. TO REFER "2RF1010-0150XX SPEC."
 5. TO CONFORM TO THE SINGATRON HAZARDOUS SUBSTANCE FREE SPEC.
 6. PRODUCT IDENTIFICATION LABEL ON PACKAGING:



NO	DESCRIPTION	QTY	MATERIAL	PLATING & COLOR
K	NUT	1	BRASS	NICKEL PLATING
J	WASHER	1	SPCC	NICKEL PLATING
I	PROTECT TUBE	1	φ2.5x15L	TRANSPARENT COLOR
H	Micro Coaxial Conn.	1	Brass (PEX 2035) or the same as	GOLD PLATING
G	WIRE	1	φ1.37 Coaxial Cable	GRAY COLOR
F	LABEL	1	20x18	WHITE COLOR
E	HEAT SHRINK TUBE	1	φ2.5x10L	BLACK COLOR
D	COPPER STOPPER	1	BRASS	NICKEL PLATING
C	CENTER CONTACT	1	BRASS	GOLD FLASH
B	INSULATOR	1	TEFLON-PTFE	WHITE COLOR
A	COPPER BODY	1	BRASS	NICKEL PLATING
NO	DESCRIPTION	QTY	MATERIAL	PLATING & COLOR

UNLESS OTHERWISE SPECIFIED TOLERANCES

DECIMALS:	ANGLES:
X : ±0.5	X : ±2°
X.X : ±0.3	X.X : ±1°
X.XX : ±0.2	

Singatron Enterprise Co., Ltd.
信音企業股份有限公司

Cable Assembly(F)

PART NO. 2RF1010-015013F
SCALE 2:1 UNIT: mm
SHEET: 1 OF 1
REV: A

CUSTOMER COPY