

REV.	ECN NO OR DESCRIPTION	REVISED	DATE
A	PDR RELEASE	IVY-C	2015.09.08

SPECIFICATIONS:

1. IMPEDANCE : 75 Ω NOMINAL
2. FREQUENCY RANGE : 2 GHz
3. VOLTAGE RATING : 335 Vrms
4. VSWR ≤ 2.0 @ 2.0 GHz
5. ROTATIONAL TORQUE : 20 lb-in min.
6. OTHER GENERAL SPEC. TO REFER "2RF1521-161107F SPEC".
7. TO CONFORM TO THE SINGATRON HAZARDOUS SUBSTANCE FREE SPEC.
8. HALOGEN FREE PRODUCT IDENTIFICATION LABEL ON PACKAGING: 
9. PACKAGE: SEE "2RF1521-161107F" PACKAGE.
10. FOR REFLOW SOLDERING LEAD-FREE PROCESS.

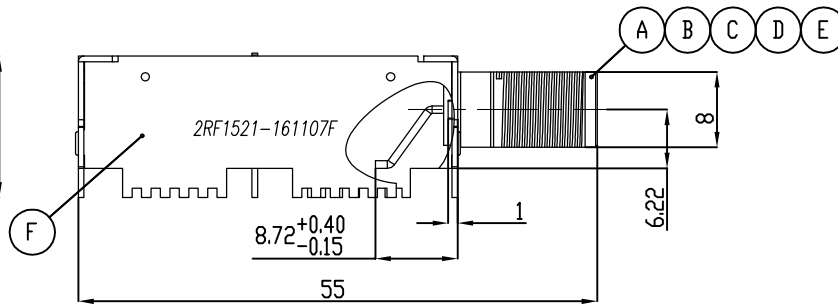
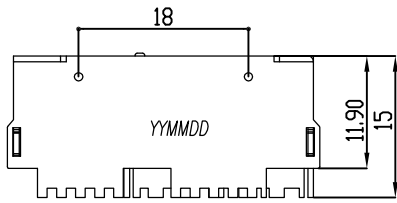
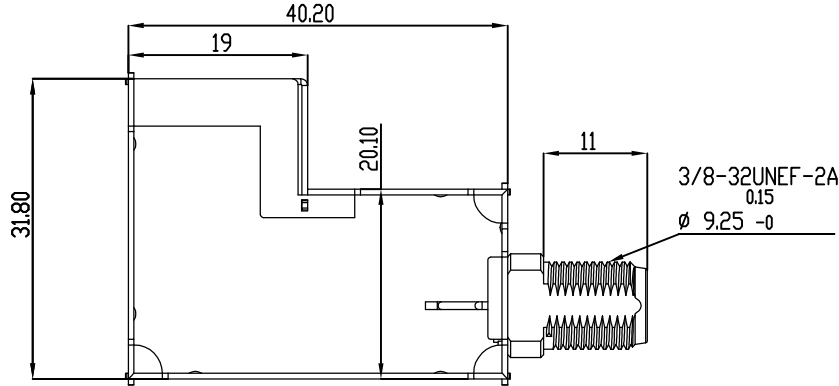
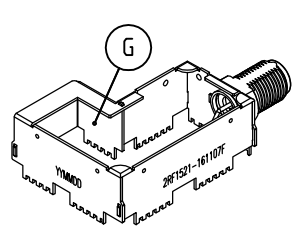

PART NO.
2RF1521-161107F

TYPE 1 _____ HALOGEN FREE
6: RIGHT ANGLE 75Ω _____ SERIAL NO.
ASSEMBLY: _____ TYPE
1: FOR PCB _____ 1: JACK WITH SHIELDING

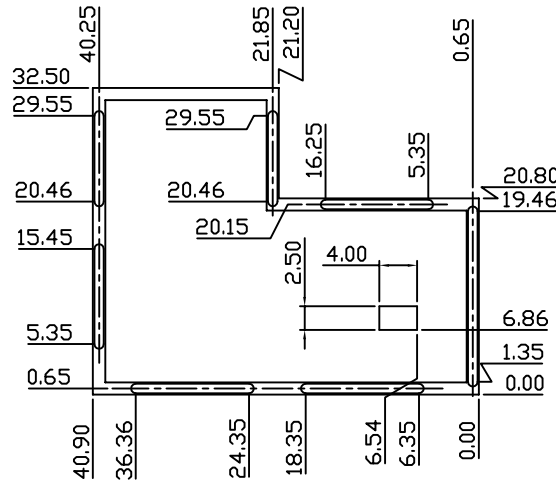
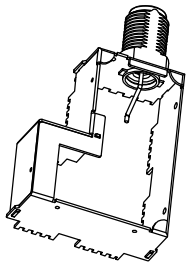

PCB LAYOUT

G	SHIELDING-1	1	SPTF	
F	SHIELDING	1	SPTF	
E	CONTACT-2	1	Phosphorous Cu (C5)	Tin PLATING
D	CONTACT-1	1	Phosphorous Cu (C5)	Tin PLATING
C	INSULATOR-2	1	PA-HTNFR52G30NH NC010	NATURAL
B	INSULATOR-1	1	PA-HTNFR52G30NH NC010	NATURAL
A	BODY	1	ZINE DIE CASTING (#3)	NICKEL PLATING
NO	DESCRIPTION	QTY	MATERIAL	PLATING & COLOR

UNLESS OTHERWISE SPECIFIED TOLERANCES

 Singatron Enterprise Co., Ltd.
信音企業股份有限公司

DECIMALS:	ANGLES:	TITLE	F-TYPE WITH SHIELDING		
X : ±0.5	X : ±2°	DWN	IVY-C 2015.09.08	PART NO. 2RF1521-161107F	
X.X : ±0.3	X.X : ±1°	CHKD	ANGELA 2015.09.08	SCALE 1:1	UNIT: mm
X.XX : ±0.2		APVD	ANGELA 2015.09.08	SIZE: A3	SHEET: 1 OF 1 REV: A

CUSTOMER COPY