

REV/ECN NO OR DESCRIPTION	REVISED	DATE
A PDR RELEASE	Even	2018.07.19

- SPECIFICATIONS:
- TO CONFORM TO THE SINGATRON HAZARDOUS SUBSTANCE FREE SPEC.
  - GREEN PRODUCT IDENTIFICATION LABEL ON PACKAGING: **GF-PASS**
  - PACKAGE: SEE "ZRF1533-000111H" PACKAGE.

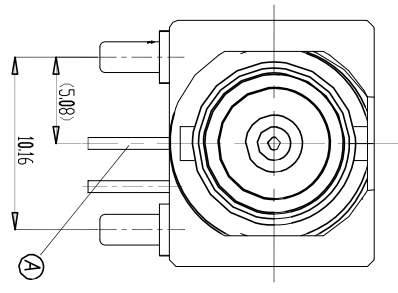
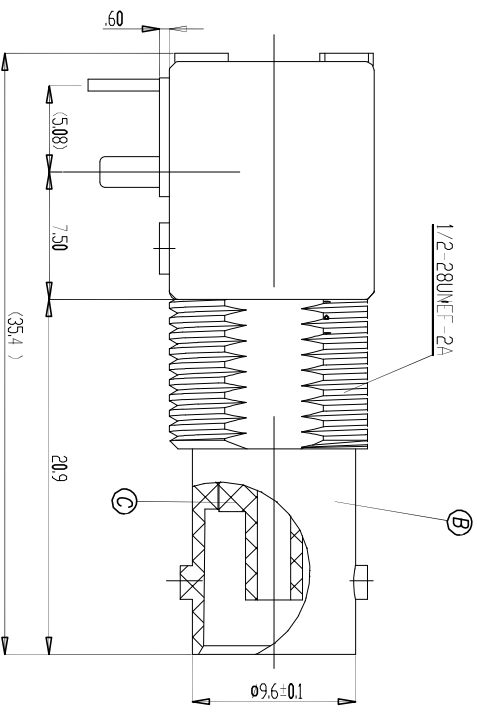
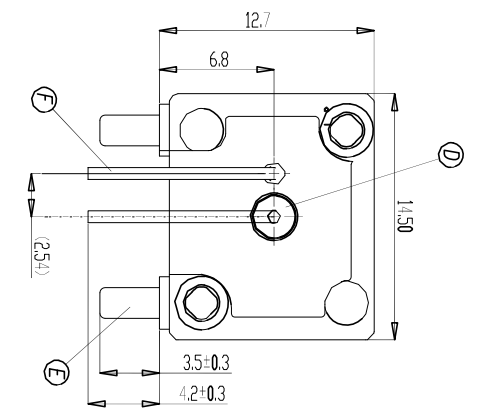
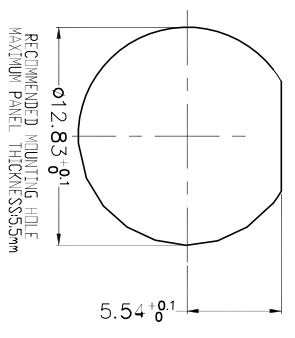
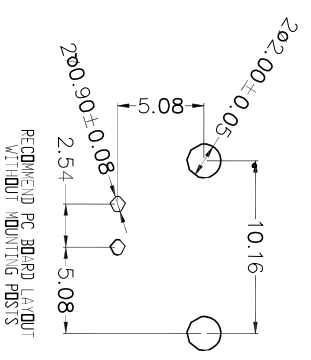

S.E(USA)  
ZBR-01131

PART NO.  
ZRF1533-000111H  
SUFFIX: HALOGEN  
PACKAGE  
1: TRAY

F	SOLDER TALL	1	COPPER WIRE	TIN PLATING
E	MOUNTING POST	1	BRASS	TIN PLATING
D	INSULATOR	1	PE-606	
C	INSULATOR	1	PE-606	
B	BODY	1	ZINC ALLOY	NICKEL
A	CENTER CONTACT	1	PHOSPHOR BRONZE	GOLD PLATING
NO	DESCRIPTION	QTY	MATERIAL	PLATING & COLOR
UNLESS OTHERWISE SPECIFIED TOLERANCES				
Singatron Enterprise Co., Ltd. 信管企業股份有限公司				
TITLE: 750 BNC R/A PCB MOUNT JACK, METAL BODY				
DWG: EBN 20180719 PART NO. ZRF1533-000111H				
CHKD: SCALE 1.25:1 UNIT: mm				
APVD: MNSL 20180719 SIZE: A3 SHEET: 1 OF 1 REV: A				
CUSTOMER COPY				

DECIMALS: ANGLES:  
X : ±0.5 X : ±2°  
X.X : ±0.5 X.X : ±1°  
X.XX : ±0.3

