

REV.	ECN NO OR DESCRIPTION	REVISED	DATE
A	PDR NO: S111027-2A	Soldier	2012.05.03

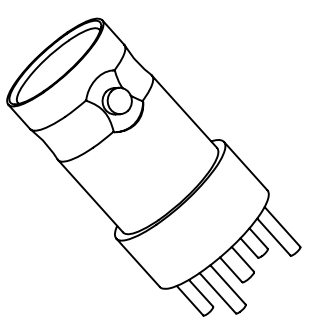
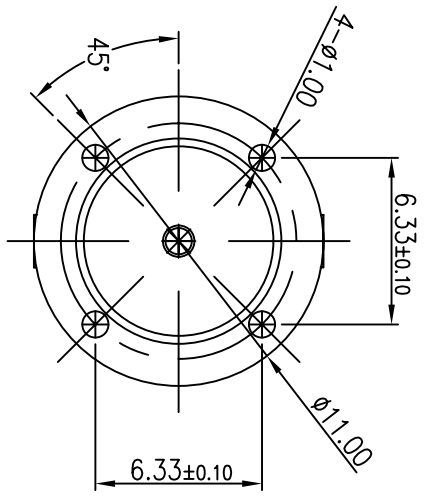
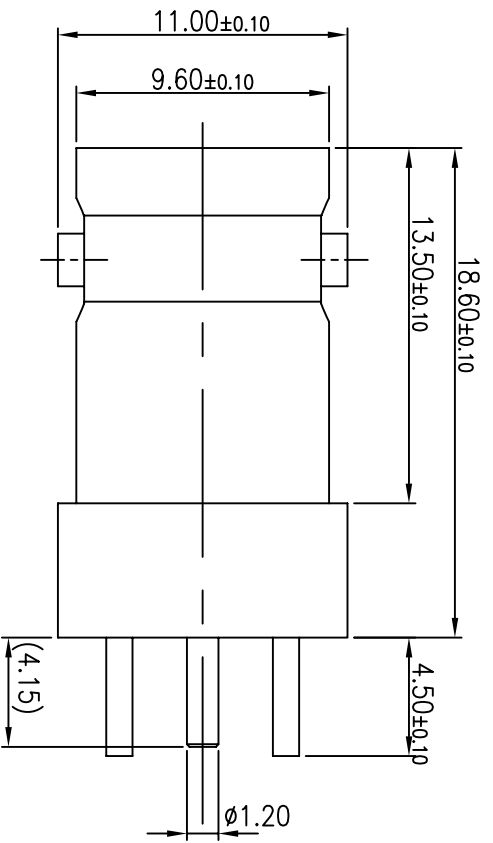

MATING PLUG

Contact Pin Definition

PIN	FUNCTION
#1	Signal
#2	Ground

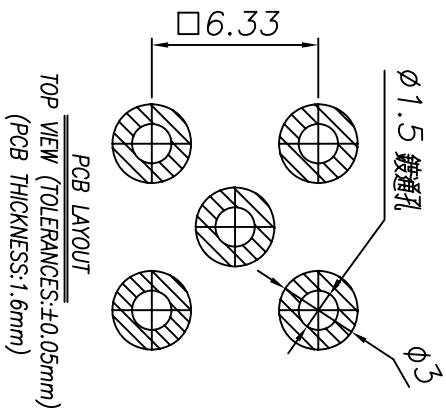
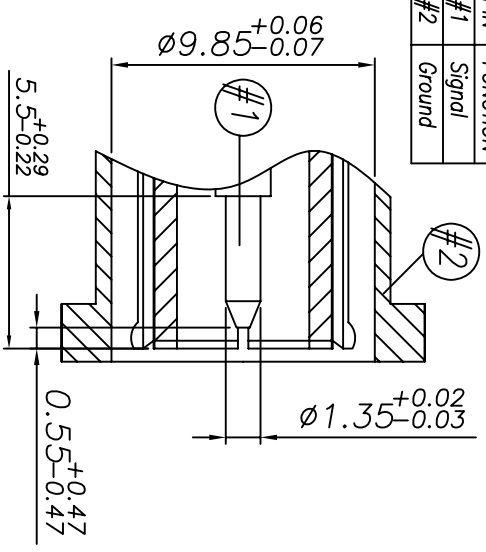

- ELECTRICAL CHARACTERISTICS :
 - IMPEDANCE : 75 OHM NOMINAL.
 - FREQUENCY RANGE : 0 ~ 1 GHz.
 - VOLTAGE RATING : 500 Vrms.
 - DIELECTRIC WITHSTANDING VOLTAGE: 1,500 Volts.
 - VSWR STRAIGHT CONNECTORS : 1.5 @1GHz (MODULUS).
- MECHANICAL CHARACTERISTICS :
 - MATING : 2-STUD BAYONET COUPLING.
 - DURABILITY (MATING) : 500 CYCLES
- OTHER GENERAL SPEC. TO REFER "2RF3005-011000F".
- TO CONFORM TO SINGATRON HAZARDOUS SUBSTANCE FREE SPEC.
- PRODUCT IDENTIFICATION LABEL ON PACKAGING:
- PACKAGING BY PET TRAY.



C	CENTER CONTACT	1	Brass	GOLD PLATED
B	INSULATOR	1	PTFE	NATURAL
A	BODY	1	TIN BRONZE	NICKEL PLATED
NO	DESCRIPTION	QTY	MATERIAL	PLATING & COLOR

UNLESS OTHERWISE SPECIFIED TOLERANCES

Singatron Enterprise Co., Ltd.
信音企業股份有限公司

DECIMALS:	ANGLES:	TITLE
X : ±0.5	X : ±2°	DWN Soldier
X.X : ±0.3	X.X : ±1°	CHKD James
X.XX : ±0.2		APVD Tony

BNC JACK

PART NO: 2RF3005-011000F

SCALE 5:1 UNIT: mm

SIZE: A3 SHEET: 10F1 REV: A

CUSTOMER COPY