

REV.	EGN NO.	OR DESCRIPTION	REVISED	DATE
A	PDR	RELEASE	NY-C	2014.05.29

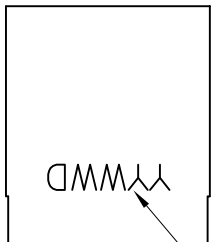

DATE CODE (C)

SPECIFICATIONS:

- VOLTAGE RATING: 125 VAC MAX.
- CURRENT RATING: 1.5 AMP MAX.
- CONTACT RESISTANCE: 40 MILLIOHMS MAX.
- INSULATION RESISTANCE: 1000M OHMS MIN. AT 500 VDC.
- DIELECTRIC WITHSTANDING VOLTAGE: 1000 VAC 60Hz 1 MINUTE.
- DURABILITY: 750 CYCLES.
- PCB RETENTION PRE-SOLDER: 1 LB MIN.
- PCB RETENTION POST-SOLDER: 10 LBS MIN.
- OPERATING TEMPERATURE: -40C TO +85C.
- TO CONFORM TO SINGATRON HAZARDOUS SUBSTANCE FREE SPEC.
- GREEN PRODUCT IDENTIFICATION LABEL ON PACKAGING: **G.P. PASS**
- PACKAGE: SEE "2RJ1704 SERIES" PACKAGE.
- FOR WAVE SOLDERING LEAD-FREE PROCESS.
- MATES WITH MODULAR PLUG CONFORMING TO FCC PART 68, SUBPART F.
- OTHER GENERAL SPEC. TO REFER "2RJ1704 SERIES SPEC".

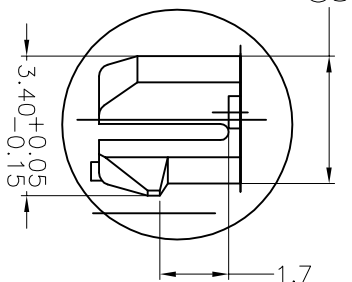
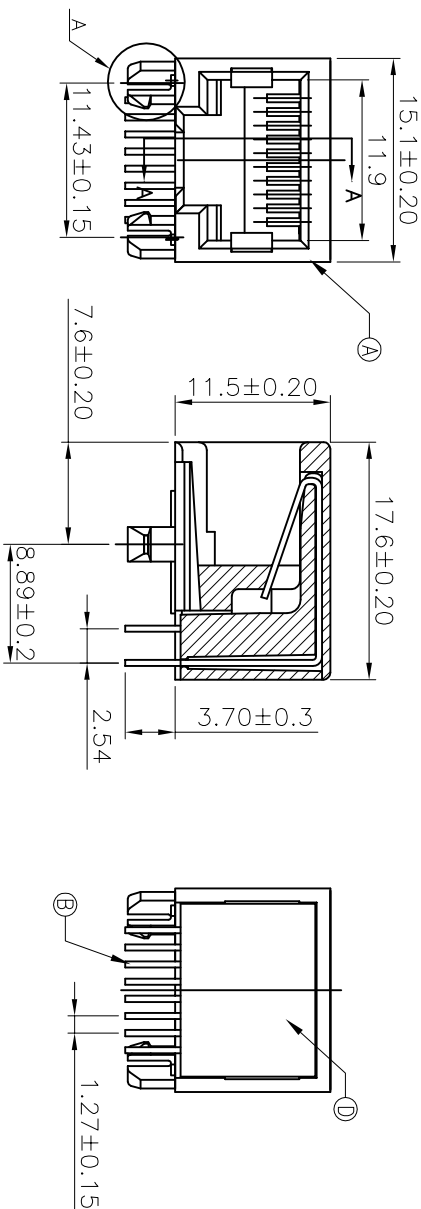

VIEW A SCALE 3:1

PC Board Layout Component Side Shown

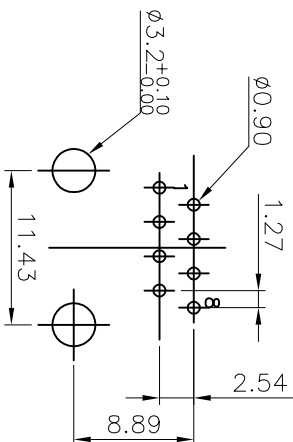

PART NO.  
2RJ1704-000111H  
SUFFIX: HALOGEN  
PACKAGE  
1: TRAY  
HOUSING COLOR  
1: YELLOW (PANTONE 114C)  
CONTACT AREA PLATING  
1: GOLD PLATING OVER 50u" MIN NICKEL

D	INSERT	THERMOPLASTIC, UL 94V-0	YELLOW
C	INK		
B	CONTACT	PBS Ø0.46mm.	SEE PART NO.
A	HOUSING	HIGH-TEMP. THERMO-PLASTIC, UL 94V-0	YELLOW
NO	DESCRIPTION	MATERIAL	PLATING & COLOR

UNLESS OTHERWISE SPECIFIED TOLERANCES

DECIMALS:	ANGLES:
X :±0.5	X :±2°
X.X :±0.3	X.X :±1°
X.XX :±0.2	

TITLE	R445 JACK, W/LED, R/A, DIP TYPE
DWN	NY-C 2014.05.29
CHKD	SCALEN/A
APVD	ANCEJAY014.05.29
SIZE: A3 SHEET: 1 OF 1 REV: A	

CUSTOMER COPY

Singatron Enterprise Co., Ltd.  
信登企業股份有限公司