

REV.	ECN NO. OR DESCRIPTION	REVISED	DATE
A	PDR NO: T180105-9A	PAN	2018.07.31

SPECIFICATIONS:

- VOLTAGE RATING: 125 VAC MAX.
- CURRENT RATING: 1.5 AMP MAX.
- CONTACT RESISTANCE: 35 MILLIOHMS MAX.
- INSULATION RESISTANCE: 1000M OHMS MIN. AT 500 VDC.
- DIELECTRIC WITHSTANDING VOLTAGE: 1000 VAC 60Hz 1 MINUTE.
- DURABILITY: 750 CYCLES.
- PCB RETENTION PRE-SOLDER: 1 LB MIN.
- PCB RETENTION POST-SOLDER: 10 LBS MIN.
- OPERATING TEMPERATURE: 0°C TO +70°C.
- TO CONFORM TO SINGATRON HAZARDOUS SUBSTANCE FREE SPEC.
- GREEN PRODUCT IDENTIFICATION LABEL ON PACKAGING: **[G.P. PASS]**
- PACKAGE: SEE "2RJ1704-001221H" PACKAGE.
- FOR WAVE SOLDERING LEAD-FREE PROCESS.
- MATES WITH MODULAR PLUG CONFORMING TO FCC PART 68, SUBPART F.

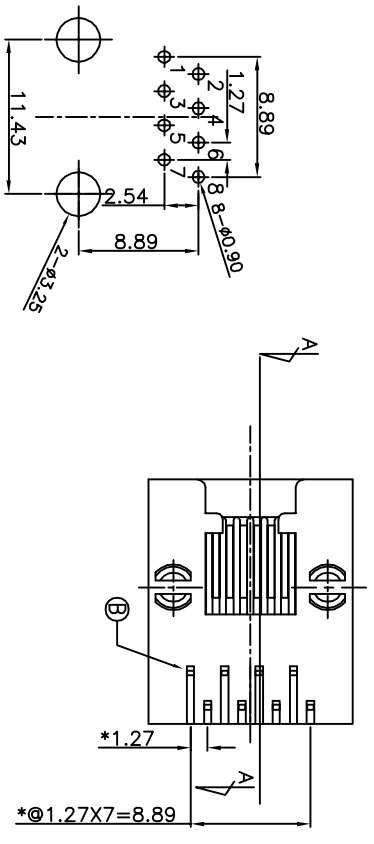
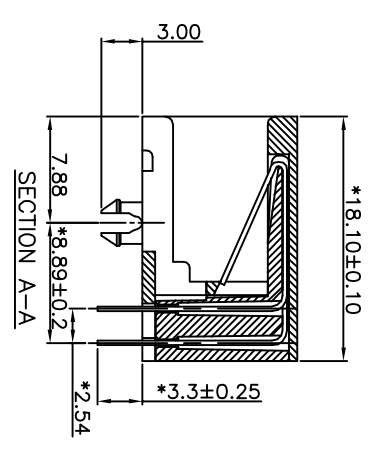
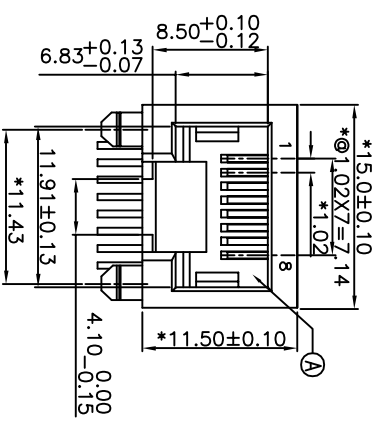

PART NO.
2RJ1704-001221H

- SUPPLY: HALOGEN
- PACKAGE 1: TRAY
- HOUSING COLOR 2: BLACK
- CONTACT AREA PLATING 2: 30u" GOLD ON CONTACT AREA, 80~160u" TIN ON SOLDER TAILS, 30~80u" NICKEL UNDERPLATED OVERALL

PCB T=1.60mm
PC BOARD LAYOUT COMPONENT SIDE SHOWN

NO	DESCRIPTION	QTY	MATERIAL	PLATING & COLOR
B	CONTACT	8	C5210-EH	SEE PART NO.
A	HOUSING	1	FR52	BLACK

UNLESS OTHERWISE SPECIFIED TOLERANCES

DECIMALS:	ANGLES:
X :±0.5	X :±2°
X.X :±0.3	X.X :±1°
X.XX :±0.2	

TITLE	R445 JACK, R/A, DIP TYPE
DWN	PART NO. 2RJ1704-001221H
CHKD	SCALEN/A UNIT: mm
APVD	SIZE: A3 SHEET: 1 OF 1 REV: A

CUSTOMER COPY

Singatron Enterprise Co., Ltd.
信音企業股份有限公司