

REV.	ECN NO OR DESCRIPTION	REVISED	DATE
A	PDR RELEASE	IVY-C	2015.10.22

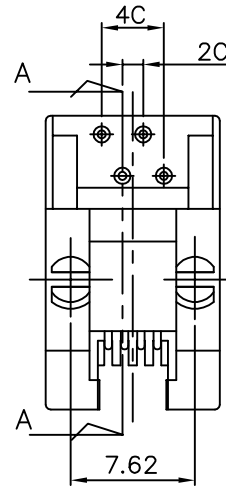
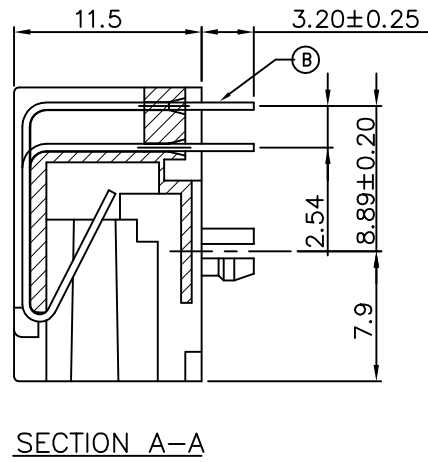
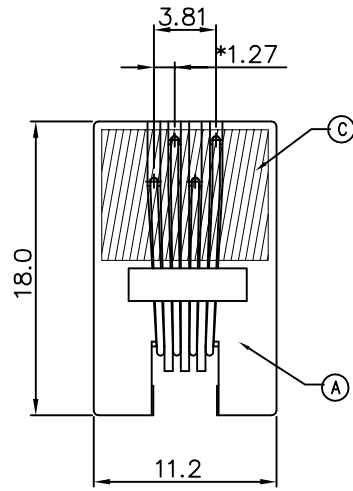

SPECIFICATIONS:

- VOLTAGE RATING: 125 VAC MAX.
- CURRENT RATING: 1.5 AMP MAX.
- INSULATION RESISTANCE: 1000M OHMS MIN. AT 500 VDC.
- DIELECTRIC WITHSTANDING VOLTAGE: 750 VAC 60Hz 1 MINUTE.
- DURABILITY: 750 CYCLES .
- OPERATING TEMPERATURE: -40°C TO +85°C.
- TO CONFORM TO SINGATRON HAZARDOUS SUBSTANCE FREE SPEC.
- HALOGEN FREE PRODUCT IDENTIFICATION LABEL ON PACKAGING: **G.P. PASS**
- PACKAGE: SEE "2RJ1708 SERIES" PACKAGE.
- FOR REFLOW SOLDERING LEAD-FREE PROCESS.
- MATES WITH MODULAR PLUG CONFORMING TO FCC PART 68, SUBPART F.
- OTHER GENERAL SPEC. TO REFER "2RJ1708-000111H SPEC".

PART NO.

2RJ1708-000111H

- SUFFIX: HALOGEN
- PACKAGE
1: TAPE AND REEL
- HOUSING COLOR
1: BLACK
- CONTACT AREA PLATING
1: GOLD FLASH PLATING OVER 50u" MIN. NICKEL

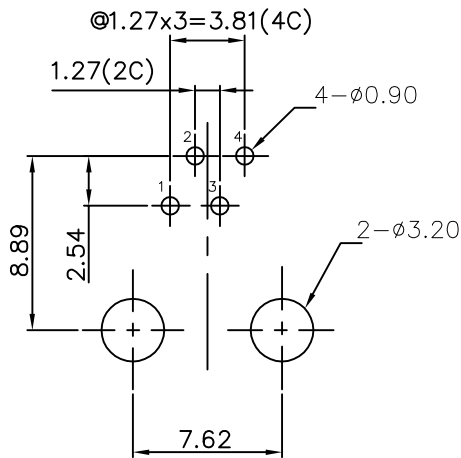

PC Board Layout
Component Side Shown

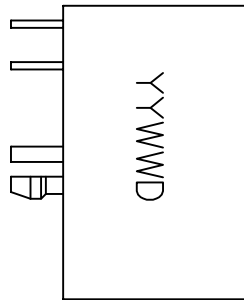

C	MYLAR	1		YELLOW
B	CONTACT	4	PHOSPHOR BRONZE	SEE PART NO.
A	HOUSING	1	HIGH-TEMP. THERMO-PLASTIC, UL 94V-0	BLACK
NO	DESCRIPTION	QTY	MATERIAL	PLATING & COLOR
UNLESS OTHERWISE SPECIFIED TOLERANCES		Singatron Enterprise Co., Ltd. 信音企業股份有限公司		
DECIMALS:	ANGLES:	TITLE	SIDE ENTRY 4P	
X : ±0.5	X : ±2°	DWN	IVY-C 2015.10.22	PART NO. 2RJ1708-000111H
XX : ±0.3	XX : ±1°	CHKD	ANGELA2015.10.22	SCALE: 1.4:1 UNIT: mm
XXX : ±0.2		APVD	ANGELA2015.10.22	SIZE: A3 SHEET: 1 OF 1 REV: A
CUSTOMER COPY				