

REV.	ECN NO OR DESCRIPTION	REVISED	DATE
A	PDR RELEASE	IVY-C	2015.09.22
B	ECN NO: L150126	IVY-C	2016.05.18
C	ECN NO: L160086	IVY-C	2016.08.02
D	ECN NO: L170001	IVY-C	2017.02.08

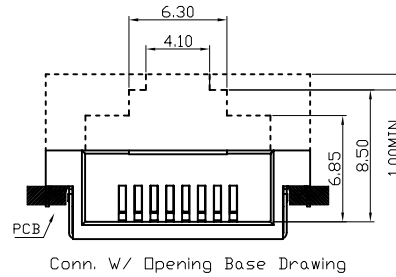

Conn. W/ Opening Base Drawing

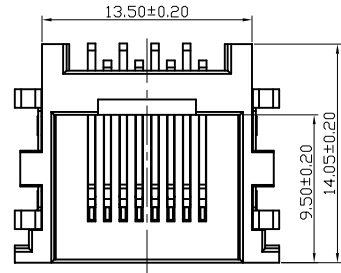
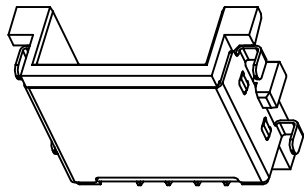
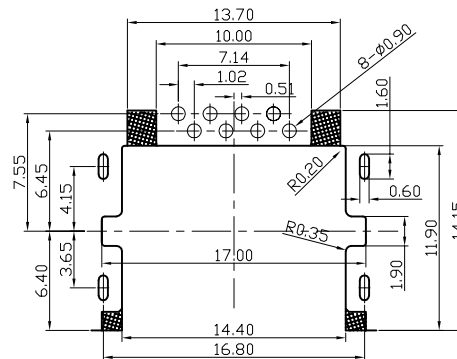
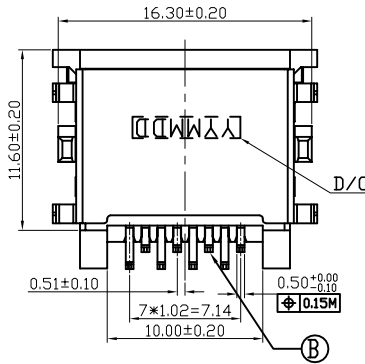
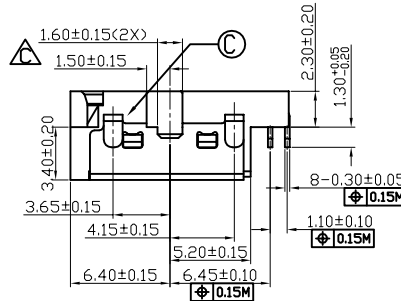
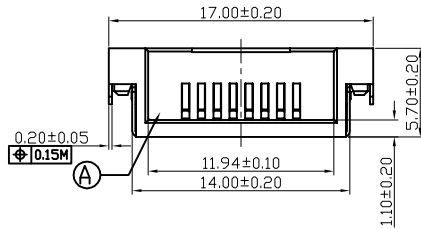
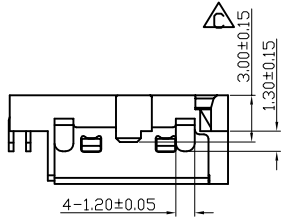

RECOMMENDED PCB LAYOUT  
TOLERANCE:±0.05mm  
RECOMMENDED PCB THICKNESS:1.60±0.05

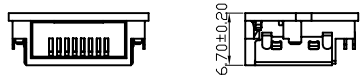
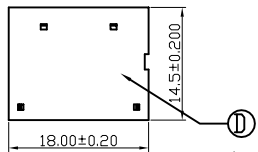

WHIT CAP DRAWING

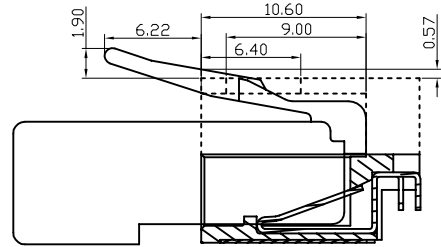

Conn. W/ Opening Base W/Plug Section Drawing

**SPECIFICATIONS:**

- VOLTAGE RATING: 150 VAC MAX.
- CURRENT RATING: 1.5 AMP MAX.
- INSULATION RESISTANCE: 1000M OHMS MIN. AT 500 VDC.
- DIELECTRIC WITHSTANDING VOLTAGE: 1000 VAC 60Hz 1 MINUTE.
- DURABILITY: 5000 CYCLES .
- OPERATING TEMPERATURE: -30°C TO +85°C.
- TO CONFORM TO SINGATRON HAZARDOUS SUBSTANCE FREE SPEC.
- HALOGEN FREE PRODUCT IDENTIFICATION LABEL ON PACKAGING: 
- PACKAGE: SEE "2RJ1745 SERIES" PACKAGE.
- FOR REFLOW SOLDERING LEAD-FREE PROCESS.
- MATES WITH MODULAR PLUG CONFORMING TO FCC PART 68, SUBPART F.
- OTHER GENERAL SPEC. TO REFER "2RJ1745-000111F SPEC".

**PART NO.**

**2RJ1745-000111F**

- SUFFIX: HALOGEN FREE
- PACKAGE  
1: TAPE & REEL
- HOUSING COLOR  
1: BLACK
- CONTACT AREA PLATING  
1: GOLD FLASH ON CONTACT AREA,  
TIN PLATED ON SOLDER AREA.  
NICKEL UNDERPLATED OVERALL.

D	CAP	1	LCP UL 94V-0	BLACK
C	SHIELD	1	STAINLESS STEEL	NICKEL
B	CONTACT	8	COPPER ALLOY	SEE PART NO.
A	HOUSING	1	PA10T UL 94V-0	BLACK
NO	DESCRIPTION	QTY	MATERIAL	PLATING & COLOR
UNLESS OTHERWISE SPECIFIED TOLERANCES			 Singatron Enterprise Co., Ltd. 信音企業股份有限公司	
DECIMALS:	ANGLES:	TITLE	RJ45 HALF JACK, W/SHIELD, DIP TYPE, H=2.30mm	
X :±0.5	X :±2°	DWN	NY-C 2017.02.08	<b>PART NO. 2RJ1745-000111F</b>
X.X :±0.3	X.X :±1°	CHKD	ANGELA2017.02.08	SCALE 3/1 UNIT: mm
X.XX :±0.2		APVD	ANGELA2017.02.08	SIZE: A3 SHEET:1 OF 1 REV: D

**CUSTOMER COPY**