

REV.	FCN NO	OR DESCRIPTION	REVISED	DATE
A	PDR	RELEASE	Even	2017.12.25

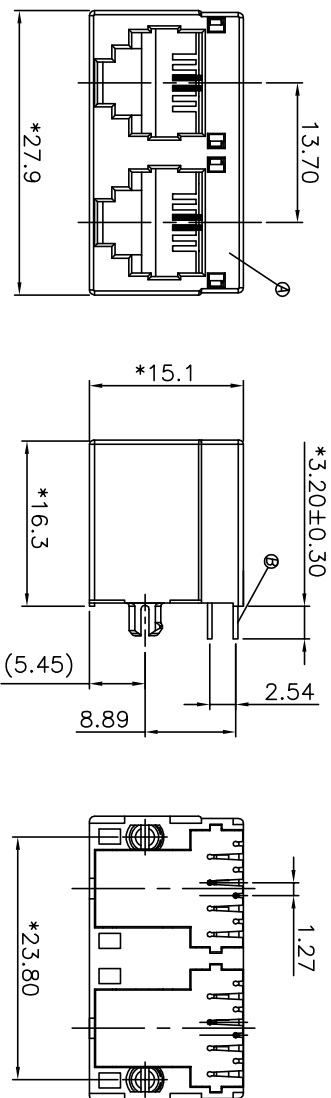

- SPECIFICATIONS:
- VOLTAGE RATING: 125 VAC MAX.
 - CURRENT RATING: 1.5 AMP MAX.
 - INSULATION RESISTANCE: 1000MΩ MIN. AT 500V DC
 - DIELECTRIC WITHSTANDING VOLTAGE: 1000 VAC 60Hz 1 MINUTE.
 - OPERATING TEMPERATURE: -40°C TO +85°C.
 - TO CONFORM TO SINGATRON HAZARDOUS SUBSTANCE FREE SPEC.
 - GREEN PRODUCT IDENTIFICATION LABEL ON PACKAGING: **[G-P-FASS]**
 - PACKAGE: SEE "2RJ1784-000111H" PACKAGE.
 - FOR WAVE SOLDERING LEAD-FREE PROCESS.
 - MATES WITH MODULAR PLUG CONFORMING TO FCC PART 68, SUBPART F.
 - DURABILITY: 750 CYCLES.
 - OTHER GENERAL SPEC. TO REFER "2RJ1784-000111H SPEC".

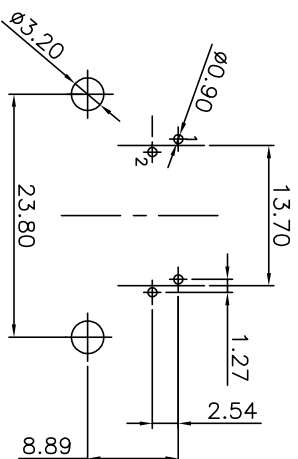

EC Board Layout Component Side Shown
EC Board Thickness=1.6mm
Tolerance±0.05

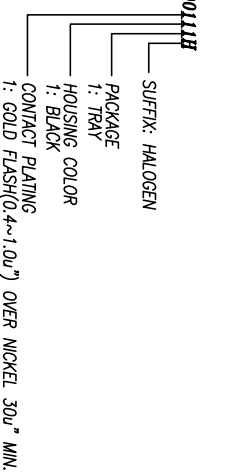

B	CONTACT	4	PHOSPHOR BRONZE	SEE PART NO.
A	HOUSING	1	PBT UJ94V-0	BLACK
NO	DESCRIPTION	QTY	MATERIAL	PLATING & COLOR
UNLESS OTHERWISE SPECIFIED TOLERANCES				
Singatron Enterprise Co., Ltd. 信管企業股份有限公司				
DECIMALS:	ANGLES:			
X : ±0.5	X : ±2°			
X.X : ±0.3	X.X : ±1'			
X.XX : ±0.2				
TITLE	TOP ENTRY GANG JACK 1*2 W/O SHIELD			
DWN	DR: 2017.12.25	PART NO.	2RJ1784-000111H	
CHKD	AMEJ2017.12.25	SCALE: 1:1	UNIT: mm	
APVD	AMEJ2017.12.25	SIZE: A3	SHEET: 1 OF 1	REV: A

CUSTOMER COPY

1 2 3 4 5 6 7 8