

SPECIFICATIONS:

- ELECTRICAL CHARACTERISTICS:
 - CURRENT RATING: 1.5A MAX.
 - VOLTAGE RATING: 150V MAX.
 - CONTACT RESISTANCE: 50mΩ MAX.(INITIAL), 100mΩ MAX.(AFTER LIFE TEST), 100mΩ MIN.
 - INSULATION RESISTANCE: 100MΩ MIN.
- MECHANICAL CHARACTERISTICS:
 - DURABILITY: 5000 CYCLES.
 - INSERTION FORCE: 2.25kg MAX. WITH LATCH DEPRESSED.
 - WITHDRAWAL FORCE: 4.5kg MAX. WITH LATCH DEPRESSED.
 - OPERATING TEMPERATURE: -30C ~ +70C.
- MARKING: MARK "S" INSIDE OF THE CONNECTOR.
- PACKAGING: TAPE & REEL.
- TO CONFORM TO SINGATRON HAZARDOUS SUBSTANCE FREE SPEC.
- HALOGEN FREE PRODUCT IDENTIFICATION
- MARK ON PRODUCT:
- HALOGEN FREE PRODUCT IDENTIFICATION LOGO ON THE PACKAGING:
- FOR REFLOW SOLDERING LEAD-FREE PROCESS.
- PRINTED DATE CODE "YY MM DD" ON TOP OF THE CONNECTOR.



REV.	ECN NO. OR DESCRIPTION	REVISED	DATE
A	PDR NO:111026-3A	Sam	2012.05.30
B	ECN NO:S140321	James	2014.05.12
C	ECN NO:S140606	James	2014.06.17

F	LED	1	YELLOW
E	LED	1	GREEN
D	SHELL-2	1	ALLOY
C	SHELL-1	1	COPPER ALLOY 0.20t
B	8P8C CONTACT	8	PHOSPHOR BRONZE 0.25t Motte Sn 120u" ON SOLDER TAIL; ALL OVER Ni 50u"MIN.
A	BODY	1	HIGH TEMP.THERMOPLASTIC UL 94V-0 & BLACK
NO. DESCRIPTION		QTY	MATERIAL
			PLATING & COLOR
UNLESS OTHERWISE SPECIFIED TOLERANCES			
DECIMALS: ANGLES:			
X	:±0.5	X	:±2°
X.X	:±0.3	X.X	:±1°
X.XX	:±0.2		



TITLE	R/45 JACK		
DWN	James	PART NO. 2RJ3024-108211F	
CHKD		SCALE 4:1	UNIT: mm
APVD	Tony	SIZE: A3	SHEET: 1 / 2
		CUSTOMER COPY	REV: C

1 2 3 4 5 6 7 8

REV.	ECN NO. OR DESCRIPTION	REVISED	DATE
A	PDR NO:111026-3A	Sam	2012.05.30
B	ECN NO:S140321	James	2014.05.12
C	ECN NO:S140606	James	2014.06.17

公母對插示意圖

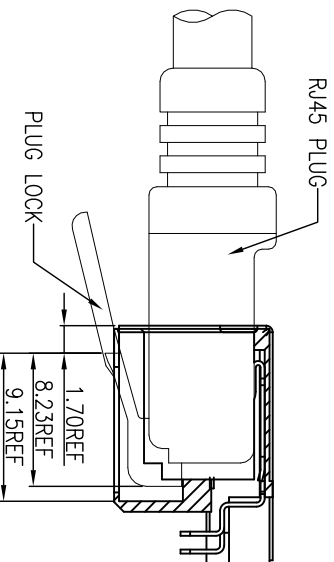

防RJ11示意圖

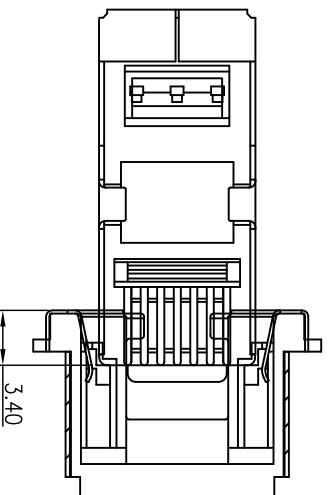

NO.	DESCRIPTION	QTY	MATERIAL	PLATING & COLOR
UNLESS OTHERWISE SPECIFIED TOLERANCES				
DECIMALS:		ANGLES:		
X	:±0.5	X	:±2°	
X.X	:±0.3	X.X	:±1°	
X.XX	:±0.2			
TITLE			RJ45 JACK	
DWN	James	PART NO.	2RJ3024-108211F	
CHKD		SCALE	4:1 UNIT: mm	
APVD	Tony	SIZE:	A3 SHEET: 2 / 2 REV: C	
CUSTOMER COPY				

 Singapore Enterprise Co., Ltd.
 信亨企業股份有限公司