

REV.	ECN NO.	DR.	DESCRIPTION	REVISED	DATE
A	PDR	NO.1170726-1A	PAN		2018.01.08

SPECIFICATIONS:

- ELECTRICAL CHARACTERISTICS:
  - CURRENT RATING: 500mA MAX.
  - VOLTAGE RATING: 150VAC MAX.
  - CONTACT RESISTANCE : 50mΩ MAX.(INITIAL), 100mΩ MAX.(AFTER LIFE TEST).
  - INSULATION RESISTANCE : 100MΩ MIN.
- MECHANICAL CHARACTERISTICS:
  - DURABILITY: 5000 CYCLES.
  - INSERTION FORCE: 2.25Kg MAX. WITH LATCH DEPRESSED.
  - WITHDRAWAL FORCE: 4.5kg MAX. WITH LATCH DEPRESSED.
  - OPERATING TEMPERATURE: -30c ~ +70c.
- MARKING: MARK "Ⓢ" INSIDE OF THE CONNECTOR.
- PACKAGING : TAPE & REEL.
- TO CONFORM TO SINGATRON HAZARDOUS SUBSTANCE FREE SPEC.
- HALOGEN FREE PRODUCT IDENTIFICATION
- HALOGEN FREE PRODUCT IDENTIFICATION LOGO
- ON THE PACKAGING: 
- FOR REFLOW SOLDERING LEAD-FREE PROCESS.
- PRINTED DATE CODE "YY MM DD " ON TOP OF THE CONNECTOR.

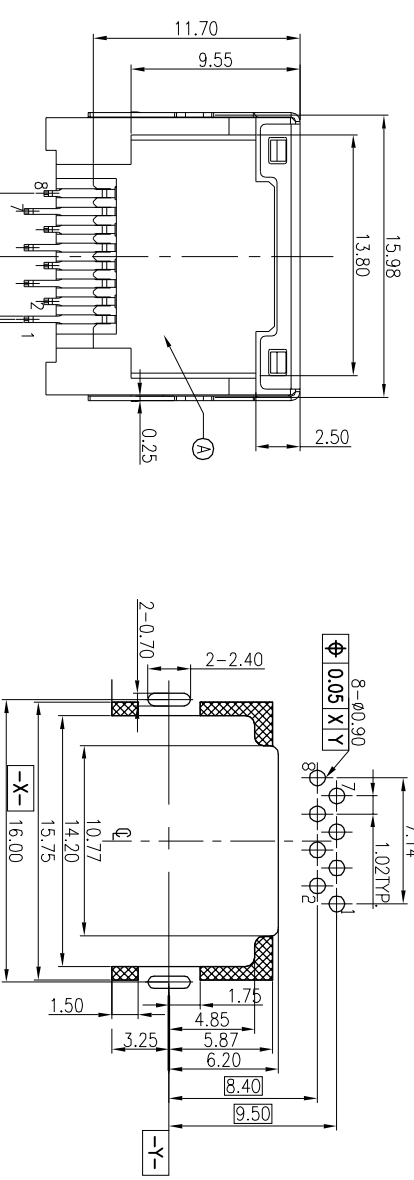
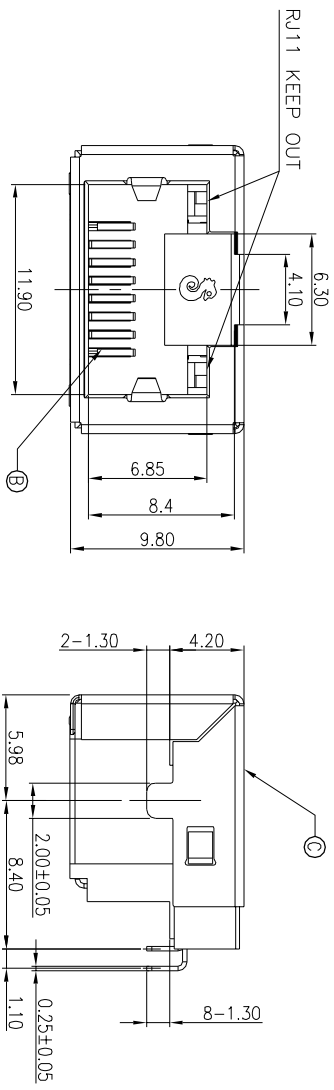
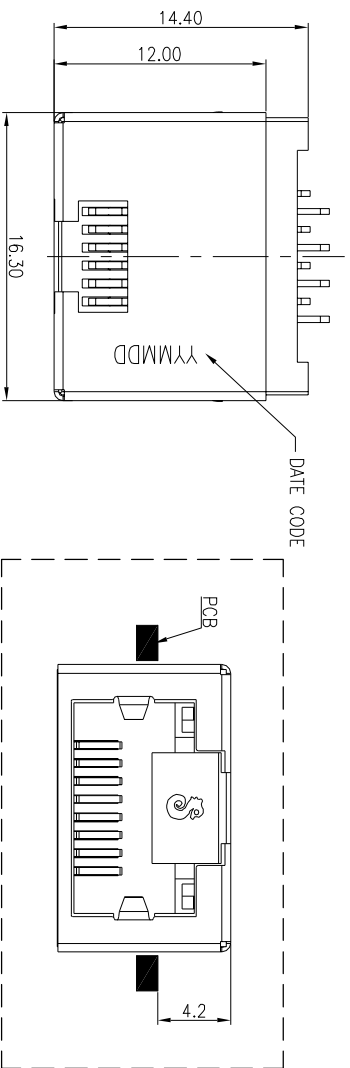

RECOMMENDED P.C.B. LAYOUT(TOP VIEW)  
PCB TOLERANCES ±0.05 / T=1.2mm  
PAD PATTERN AREA

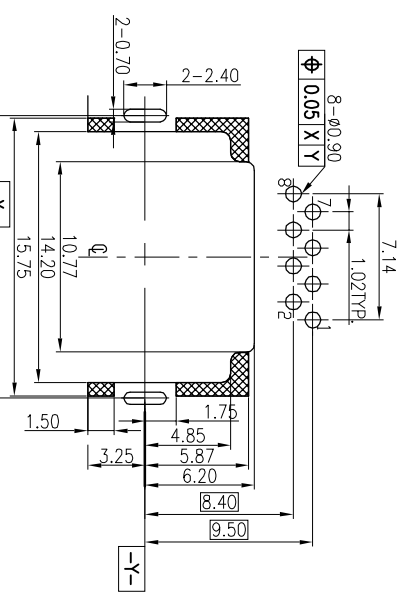

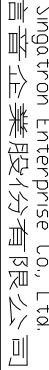
C	SHELL	1	STAINLESS	N: 50U *MIN.
B	8P8C CONTACT	8	PHOSPHOR BRONZE 0.25t	AU PLATING CONTACT AREA Sn 120U ON SOLDER TAIL; ALL OVER N: 50U *MIN.
A	BODY	1	HIGH TEMP.THERMOPLASTIC	BLACK
NO	DESCRIPTION	QTY	MATERIAL	PLATING & COLOR
UNLESS OTHERWISE SPECIFIED TOLERANCES				
 Singatron Enterprise Co., Ltd  信亨企業股份有限公司				
TITLE: RJ45 JACK				
DWN	PAN	PART NO.	2RJ3027-028211F	
CHKD	James	SCALE	4:1	UNIT: mm
APVD	Boye	SIZE:	A3	SHEET: 1 / 1
REV: A				
CUSTOMER COPY				

