

REV.	ECN NO. OR DESCRIPTION	REVISED	DATE
A	PDR NO.:T131009-2A	ALLEN	2014.05.20
B	EGR NO.:S151014-E	ALLEN	2015.10.19
C	ECN NO.:S181235-R	Colour	2018.12.17

SPECIFICATIONS:

- ELECTRICAL CHARACTERISTICS:**
 - CURRENT RATING: 1.5A MAX.
 - VOLTAGE RATING: 150V MAX.
 - CONTACT RESISTANCE : 50mΩ MAX.(INITIAL), 100mΩ MAX.(AFTER LIFE TEST).
 - INSULATION RESISTANCE : 100MΩ MIN.
- MECHANICAL CHARACTERISTICS:**
 - DURABILITY: 5000 CYCLES.
 - INSERTION FORCE: 2.25kg MAX. WITH LATCH DEPRESSED.
 - WITHDRAWAL FORCE: 4.5kg MAX. WITH LATCH DEPRESSED.
 - OPERATING TEMPERATURE: -30℃ ~ +70℃.
- MARKING: MARK "S" INSIDE OF THE CONNECTOR.
- PACKAGING : TAPE & REEL.
- TO CONFORM TO SINGATRON HAZARDOUS SUBSTANCE FREE SPEC.
- HALOGEN FREE PRODUCT IDENTIFICATION
- MARK ON PRODUCT:  ON THE PACKAGING.
- HALOGEN FREE PRODUCT IDENTIFICATION LOGO
- FOR REFLOW SOLDERING: LEAD-FREE PROCESS.
- PRINTED DATE CODE "YY MM DD" ON TOP OF THE CONNECTOR.

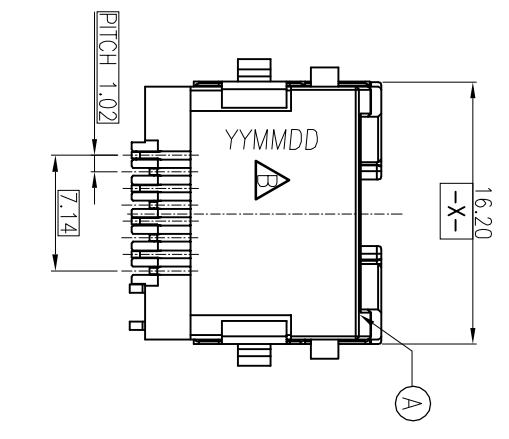
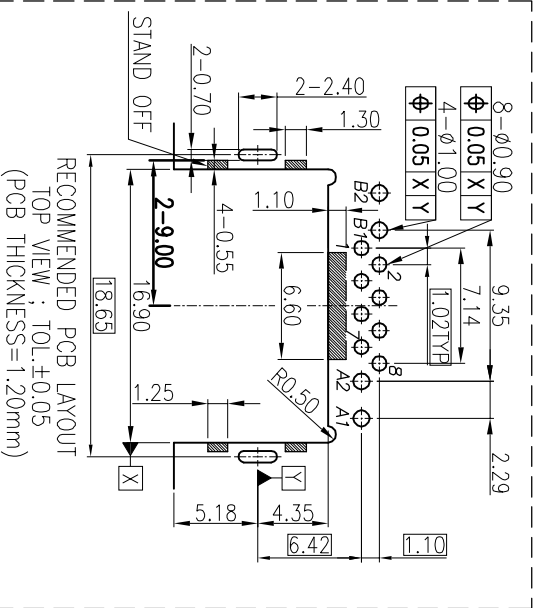
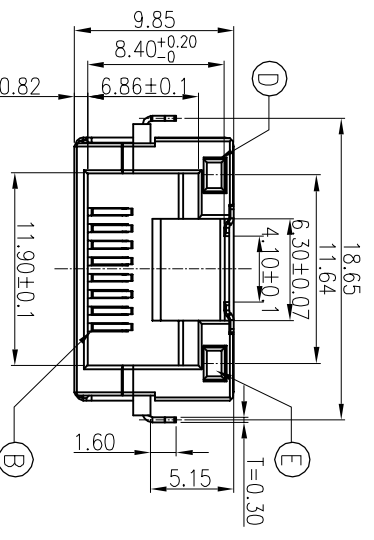
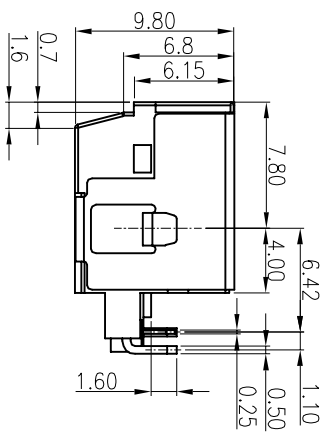
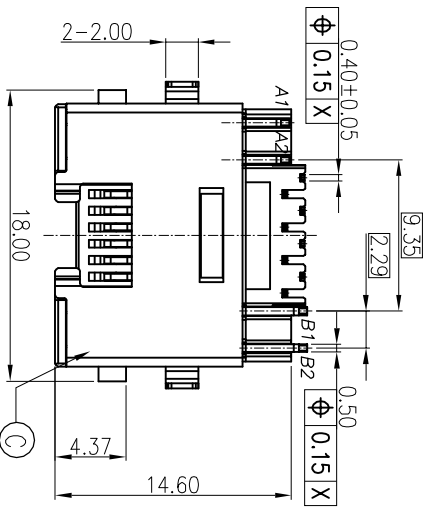
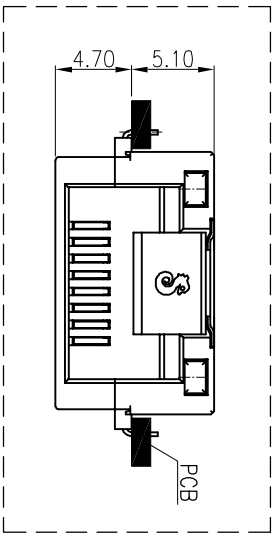

NODE	COLOR	Wavelength
A1(+)	A2(-)	YELLOW
B1(+)	B2(-)	GREEN

NO.	DESCRIPTION	QTY	MATERIAL	PLATING & COLOR
E	LED	1		GREEN
D	SHELL	1	Stainless Steel	YELLOW
C	8P8C CONTACT	8	PHOSPHOR BRONZE	NI PLATING ALL OVER
B	BODY	1	PA10T	C/F ON CONTACT AREA: Motte Sn 120u" ON SOLDER TAIL: ALL OVER NI 50u"MIN.
A		1	UL 94V-0 & BLACK	

Singatron Enterprise Co., Ltd.
信登企業股份有限公司

TITLE	DECIMALS:	ANGLES:
DWN	±0.5	X ±2°
CHKD	±0.3	XX ±1°
APVD	XXX ±0.2	

TITLE	PART NO.	SCALE	UNIT:	SHEET:1 / 2	REV: C
RJ45 JACK	2RJ3030-1A8211F	4:1	mm		

CUSTOMER COPY

REV.	ECN NO. OR DESCRIPTION	REVISED	DATE
A	PDR NO.:131009-2A	ALLEN	2014.05.20
B	EGR NO.:S151014-E	ALLEN	2015.10.19
C	ECN NO.:S181235-R	Colour	2018.12.17

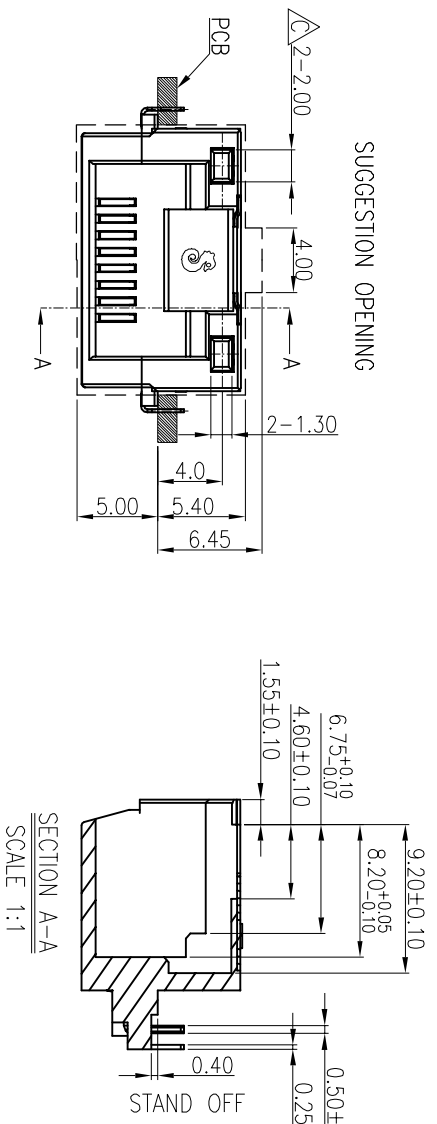
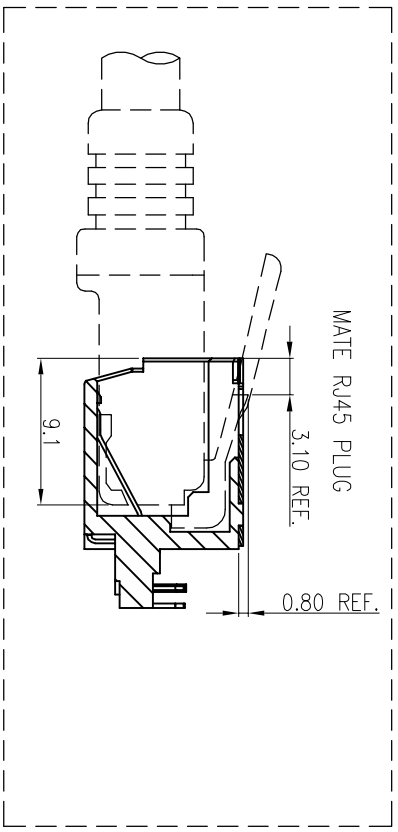

NO	DESCRIPTION	QTY	MATERIAL	PLATING & COLOR
E	LED	1		GREEN
D	LED	1		YELLOW
C	SHELL	1	Stainless Steel	NI PLATING ALL OVER
B	8P8C CONTACT	8	PHOSPHOR BRONZE	C/F ON CONTACT AREA: Matte Sn 120u" ON SOLDER TAIL: ALL OVER NI 50u"MIN.
A	BODY	1	PA10T	UL 94V-0 & BLACK

UNLESS OTHERWISE SPECIFIED TOLERANCES

 Singatron Enterprise Co., Ltd.
信管企業股份有限公司

TITLE	RJ45 JACK	
DWN	PART NO. 2RJ3030-1A8211F	
CHKD	SCALE 4:1	UNIT: mm
APVD	SIZE: A3	SHEET: 2 / 2
	CUSTOMER	COPY

