

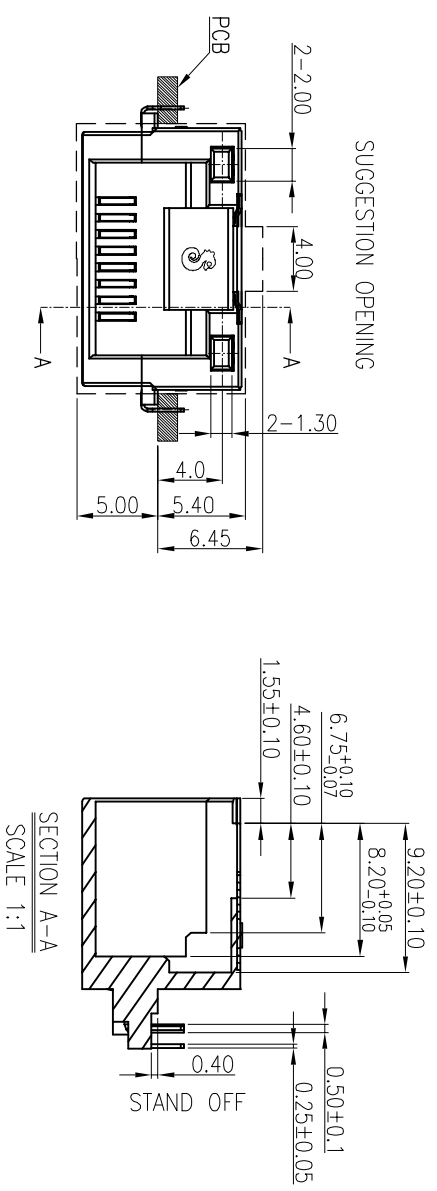

REV.	ECN NO. OR DESCRIPTION	REVISED	DATE
A	PDR NO.:181206-8A	PAN	2019.07.31

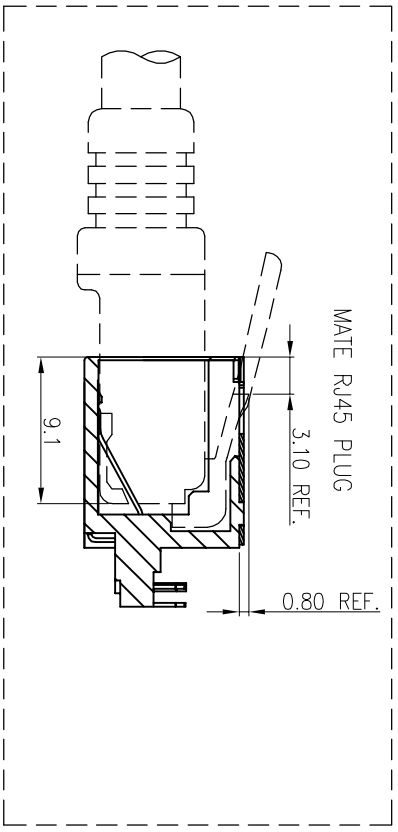

NO.	DESCRIPTION	QTY	MATERIAL	PLATING & COLOR
	UNLESS OTHERWISE SPECIFIED TOLERANCES			
	DECIMALS: ANGLES:			
X	±0.5	X	±2°	
X,X	±0.3	X,X	±1°	
X,XX	±0.2			
TITLE: RJ45 JACK				
DWN	PAN	PART NO. 2RJ3030-1M8211F		
CHKD	JAMES	SCALE 4:1	UNIT: mm	
APVD	BOYE	SIZE: A3	SHEET: 2 / 2	REV: A
CUSTOMER COPY				

 Singapore Enterprise Co., Ltd.
 信晉企業股份有限公司

