

REV.	ECN NO OR DESCRIPTION	REVISED	DATE
A	PDR NO:T230519-1A	JIANGTAO	2023.07.26

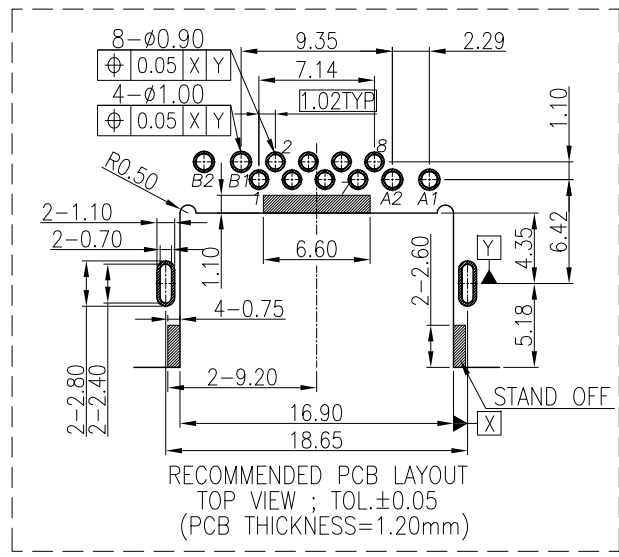
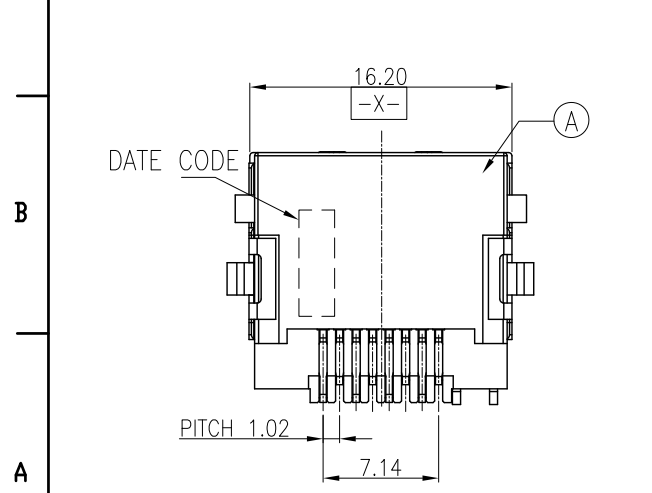
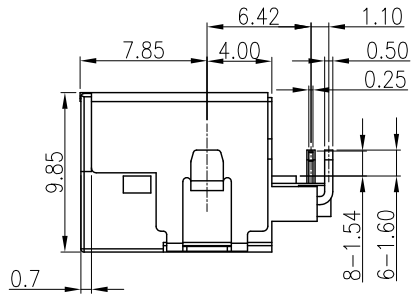
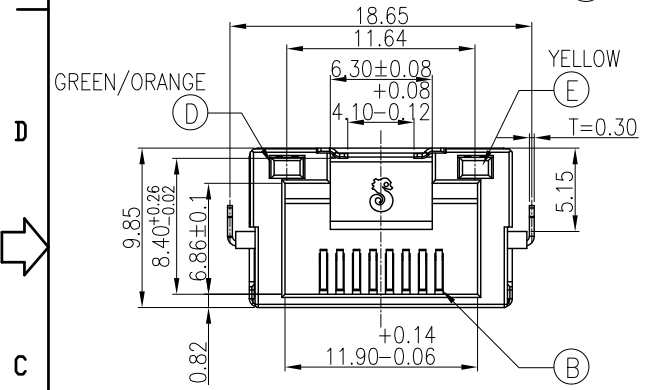
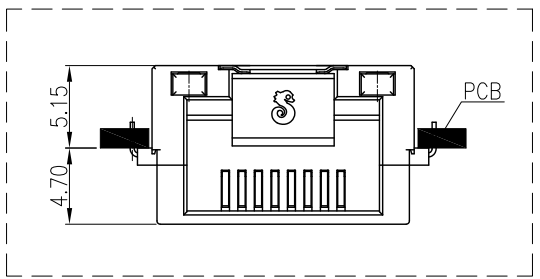
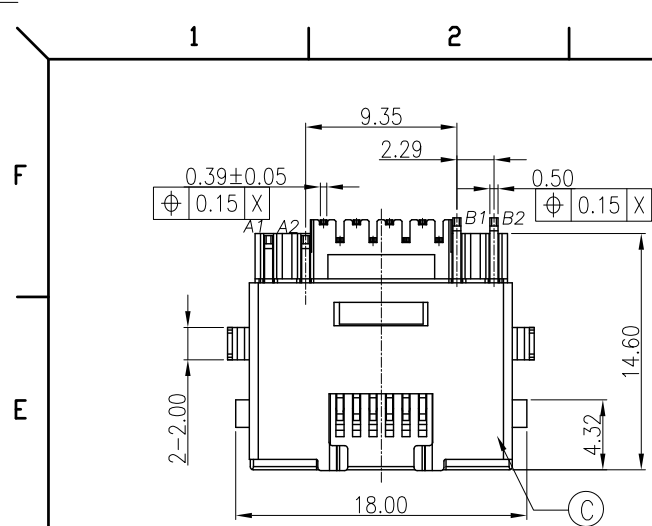

SPECIFICATIONS:

- ELECTRICAL CHARACTERISTICS:
 - CURRENT RATING: 1.5A MAX.
 - VOLTAGE RATING: 150V MAX.
 - CONTACT RESISTANCE : 50mΩ MAX.(INITIAL).
100mΩ MAX.(AFTER LIFE TEST).
 - INSULATION RESISTANCE : 100MΩ MIN.
- MECHANICAL CHARACTERISTICS:
 - DURABILITY: 5000 CYCLES.
 - INSERTION FORCE: 2.25Kg MAX. WITH LATCH DEPRESSED.
 - WITHDRAWAL FORCE: 4.5Kg MAX. WITH LATCH DEPRESSED.
 - OPERATING TEMPERATURE: -30℃ ~ +70℃.
- MARKING: MARK "S" INSIDE OF THE CONNECTOR.
- PACKAGING : TAPE & REEL.
- TO CONFORM TO SINGATRON HAZARDOUS SUBSTANCE FREE SPEC.
- HALOGEN FREE PRODUCT IDENTIFICATION
MARK ON PRODUCT:
- HALOGEN FREE PRODUCT IDENTIFICATION LOGO
ON THE PACKAGING:
- FOR REFLOW SOLDERING LEAD-FREE PROCESS.
- PRINTED DATE CODE "YY MM DD" ON TOP OF THE CONNECTOR.

DD: DAY
MM: MONTH
YY: YEAR

NODE	COLOR	Wavelength	DC Forward Current	Forward Voltage
B2(-) B1(+)	YELLOW	λd 585~597	20mA	1.7~2.7V
A2(+)	A1(-)	GREEN	λd 565~574	20mA
A2(-)	A1(+)	ORANGE	λd 600~612	20mA

E	LED	1	YELLOW	
D	LED	1	GREEN/ORANGE	
C	SHELL	1	Stainless Steel BLACK NI PLATING ALL OVER	
B	8P8C CONTACT	8	PHOSPHOR BRONZE 15U" AU ON CONTACT AREA; Matte Sn 120u" ON SOLDER TAIL; ALL OVER Ni 50u"MIN.	
A	BODY	1	PA10T UL 94V-0 & BLACK	
NO	DESCRIPTION	QTY	MATERIAL	PLATING & COLOR

UNLESS OTHERWISE SPECIFIED TOLERANCES		Singatron Enterprise Co., Ltd. 	
DECIMALS:	ANGLES:	TITLE	RJ45 JACK
X : ±0.5	X : ±2°	DWN	JIANGTAO PART NO. 2RJ3030-1Q8211F
X.X : ±0.3	X.X : ±1°	CHKD	ALLEN SCALE 4:1 UNIT: mm
X.XX : ±0.2		APVD	BOYE SIZE: A3 SHEET: 1 / 2 REV: A
CUSTOMER COPY			

1 2 3 4 5 6 7 8

REV.	ECN NO OR DESCRIPTION	REVISED	DATE
A	PDR NO:T230519-1A	JIANGTAO	2023.07.26

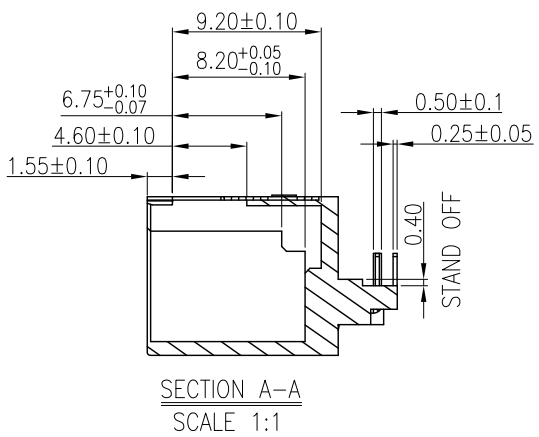
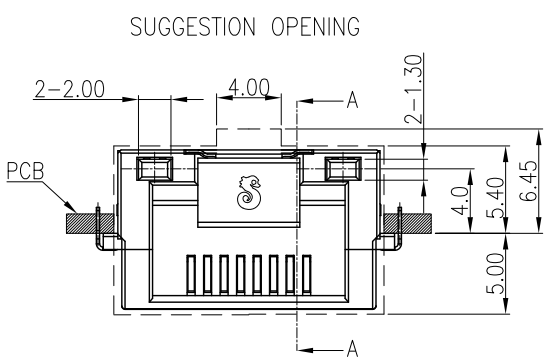
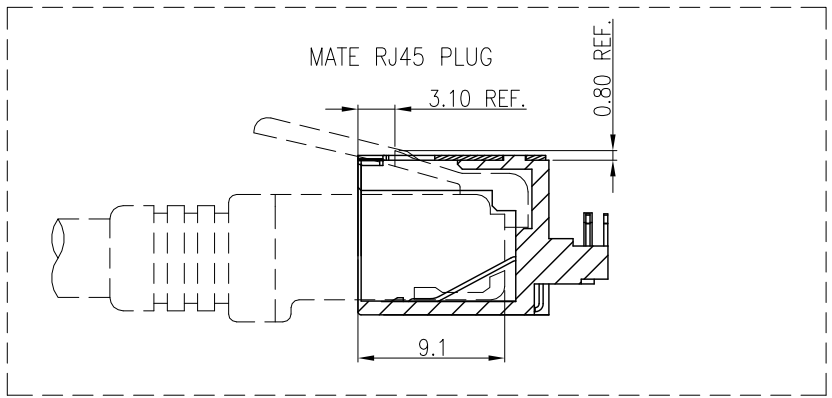

NO	DESCRIPTION	QTY	MATERIAL	PLATING & COLOR
UNLESS OTHERWISE SPECIFIED TOLERANCES			Singatron Enterprise Co., Ltd. 信音企業股份有限公司	
DECIMALS: X ±0.5		ANGLES: X ±2°		TITLE RJ45 JACK
X.X ±0.3		X.X ±1°		DWN JIANGTAO PART NO. 2RJ3030-1Q8211F
X.XX ±0.2		CHKD ALLEN	SCALE 4:1	UNIT: mm
		APVD BOYE	SIZE: A3	SHEET: 2 / 2
CUSTOMER COPY				

1 2 3 4 5 6 7 8