

REV.	ECN NO OR DESCRIPTION	REVISED	DATE
A	PDR NO:S120718-11A	JAMES	2012.11.12
B	ECR NO:S151011-C	Charles	2015.12.25
C	ECN NO:S170231-C	peng	2017.04.12

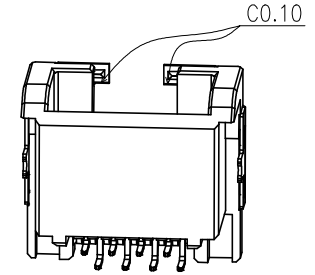
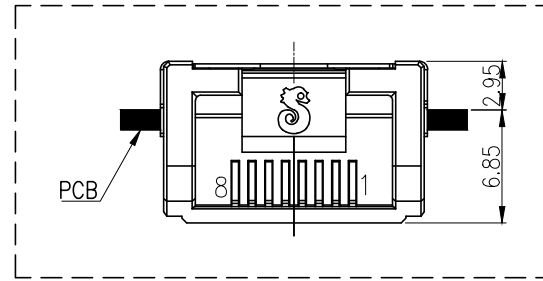
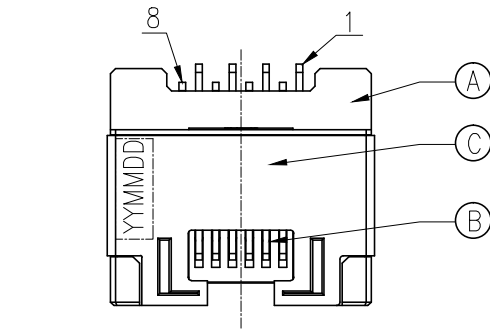

SPECIFICATIONS:

- ELECTRICAL CHARACTERISTICS:
 - 1-1. CURRENT RATING: 0.5A MAX.
 - 1-2. VOLTAGE RATING: 150V MAX.
 - 1-3. CONTACT RESISTANCE: 50mΩ MAX.(INITIAL), 100mΩ MAX.(AFTER LIFE TEST).
 - 1-4. INSULATION RESISTANCE: 100MΩ MIN.
- MECHANICAL CHARACTERISTICS:
 - 2-1. DURABILITY: 5000 CYCLES.
 - 2-2. INSERTION FORCE: 2.25Kg MAX. WITH LATCH DEPRESSED.
 - 2-3. WITHDRAWAL FORCE: 4.5Kg MAX. WITH LATCH DEPRESSED.
 - 2-4. OPERATING TEMPERATURE: -30℃ ~ +70℃
- MARKING: MARK "S" INSIDE OF THE CONNECTOR.
- PACKAGING: TAPE & REEL.
- TO CONFORM TO SINGATRON HAZARDOUS SUBSTANCE FREE SPEC.
- HALOGEN FREE PRODUCT IDENTIFICATION
MARK ON PRODUCT:
- HALOGEN FREE PRODUCT IDENTIFICATION LOGO
ON THE PACKAGING:
- FOR REFLOW SOLDERING LEAD-FREE PROCESS.
- PRINTED DATE CODE "YY MM DD" ON TOP OF THE CONNECTOR.

DD: DAY
MM: MONTH
YY: YEAR

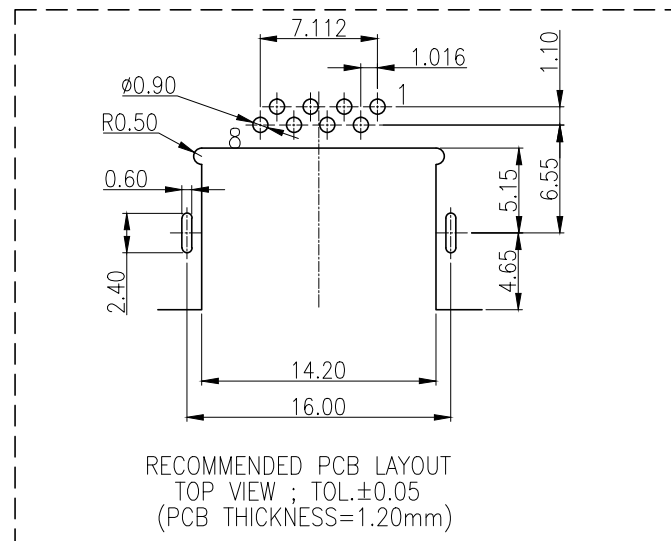
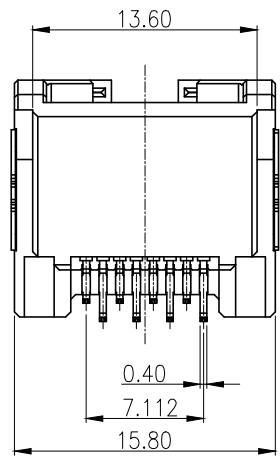
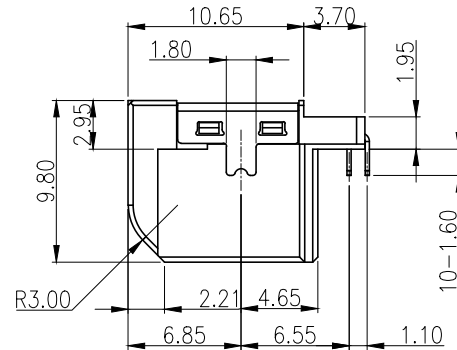
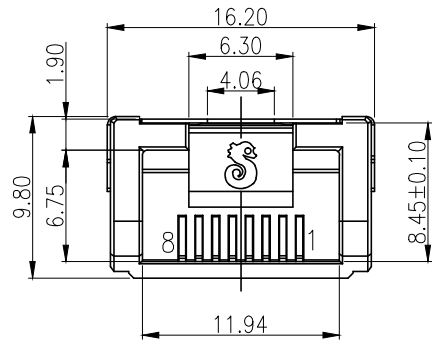

C	SHELL	1	STAINLESS STEEL	NI PLATING
B	8P8C CONTACT	8	PHOSPHOR BRONZE	Au 1u"MIN ON CONTACT AREA; Matte Sn 120u" ON SOLDER TAIL; ALL OVER Ni 50u"MIN.
A	BODY	1	HIGH TEMP.THERMOPLASTIC	UL 94V-0 & BLACK
NO	DESCRIPTION	QTY	MATERIAL	PLATING & COLOR

UNLESS OTHERWISE SPECIFIED TOLERANCES

Singatron Enterprise Co., Ltd.
信音企業股份有限公司

DECIMALS:	ANGLES:	TITLE	RJ45 JACK		
X :±0.5	X :±2°	DWN peng	PART NO. 2RJ3036-008211F		
X.X :±0.3	X.X :±1°	CHKD james	SCALE 4:1	UNIT: mm	
X.XX :±0.2		APVD boye	SIZE: A3	SHEET:1 / 1	REV: C
CUSTOMER COPY					