

REV.	ECN NO. OR DESCRIPTION	REVISED	DATE
A	PDR NO:S141201-2A	JAMES	2015.01.28
B	ECN NO:S150431-0	JAMES	2015.06.09

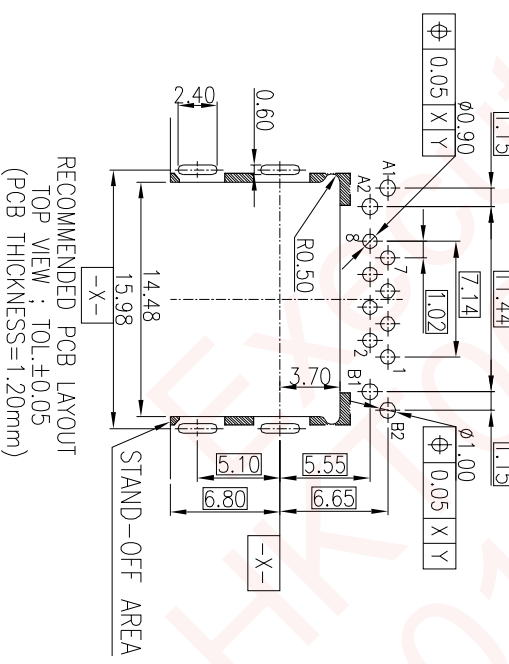

SPECIFICATIONS:

- ELECTRICAL CHARACTERISTICS:**
 - 1-1. CURRENT RATING: 0.5A MAX.
 - 1-2. VOLTAGE RATING: 150V MAX.
 - 1-3. CONTACT RESISTANCE : 50mΩ MAX.(INITIAL), 100mΩ MAX.(AFTER LIFE TEST).
 - 1-4. INSULATION RESISTANCE: 100MΩ MIN.
- MECHANICAL CHARACTERISTICS:**
 - 2-1. DURABILITY: 5000 CYCLES.
 - 2-2. INSERTION FORCE: 2.1kg MAX. WITHOUT LATCH.
 - 2-3. EXTRACTION FORCE: 3.0kg MIN. WITH LATCH.
 - 2-4. OPERATING TEMPERATURE:-30℃ ~ +70℃.
- MARKING: MARK "S" INSIDE OF THE CONNECTOR.
- PACKAGING : TAPE & REEL.
- TO CONFORM TO SINGATRON HAZARDOUS SUBSTANCE FREE SPEC.
- HALOGEN FREE PRODUCT IDENTIFICATION
- MARK ON PRODUCT:
- HALOGEN FREE PRODUCT IDENTIFICATION LOGO ON THE PACKAGING:
- FOR REFLOW SOLDERING LEAD-FREE PROCESS.
- PRINTED DATE CODE "YY MM DD " ON TOP OF THE CONNECTOR.

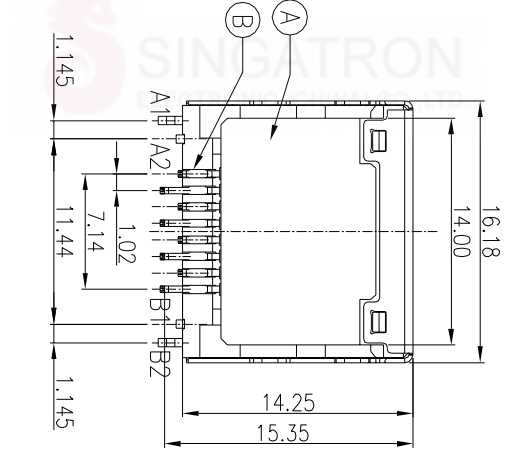
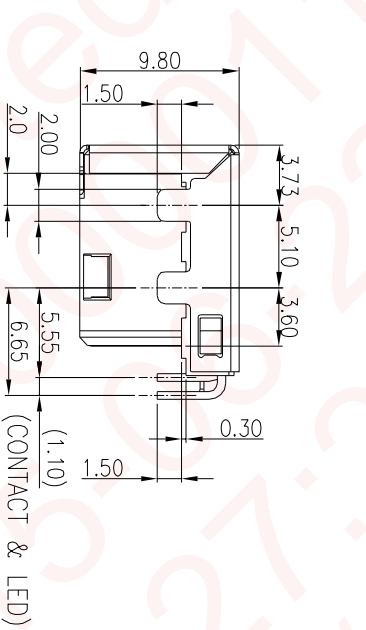
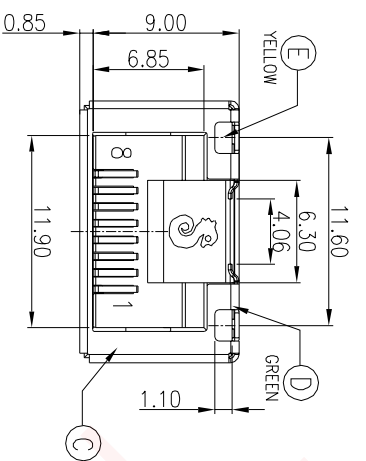
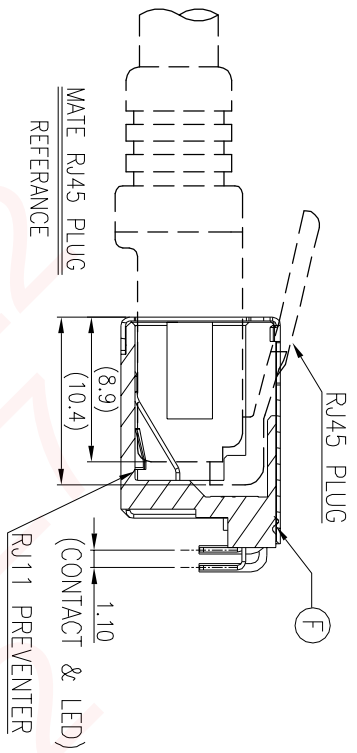
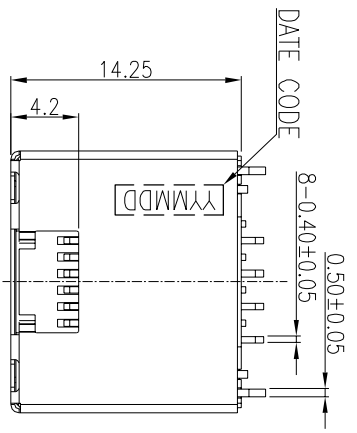

MODE	COLOR	A1→A2
A1(+)	AZ(-)	YELLOW
B1(+)	B2(-)	GREEN

NO	DESCRIPTION	QTY	MATERIAL	PLATING & COLOR
F	MYLAR	1		YELLOW
E	LED	1		YELLOW
D	LED	1		GREEN
C	SHELL	1	STAINLESS STEEL T:0.25mm	NI PLATING ALL OVER
B	8P8C CONTACT	8	PHOSPHOR BRONZE T:0.25mm	5u" Au ON CONTACT AREA: Matte Sn 120u" ON SOLDER TAIL: ALL OVER Ni 50u"MIN.
A	BODY	1	HIGH TEMP.THERMOPLASTIC	UL 94V-0 & BLACK

Singatron Enterprise Co., Ltd.
信置企業股份有限公司

DECIMALS:	ANGLES:	TITLE
X : ±0.5	X : ±2°	RJ45 JACK
X.X : ±0.3	X.X : ±1°	DWN PART NO. 2RJ3047-128411F
X.XX : ±0.2		CHKD SCALE 4:1 UNIT: mm
		APVD BOYE SIZE: A3 SHEET: 1 / 1 REV: B