

REV	ECN NO OR DESCRIPTION	REVISED	DATE
A	PDR NO:1781128-3B	PAN	2019.06.19

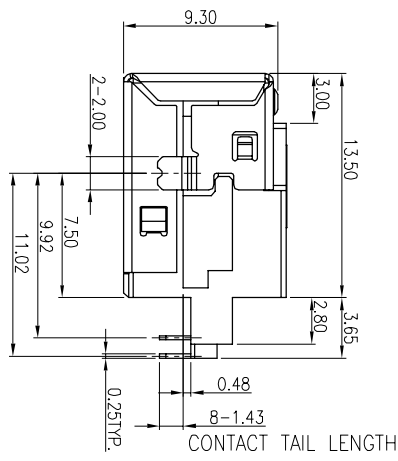

CONTACT TAIL LENGTH

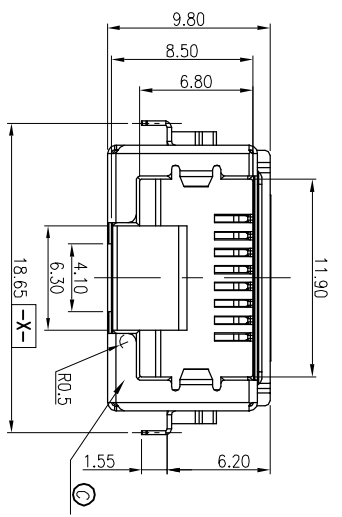
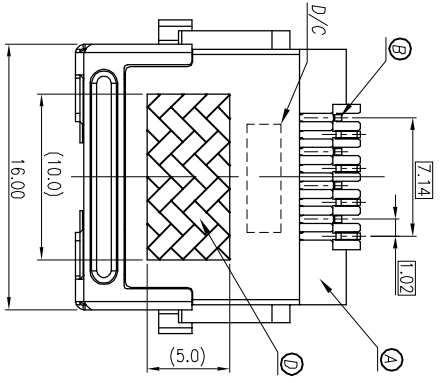
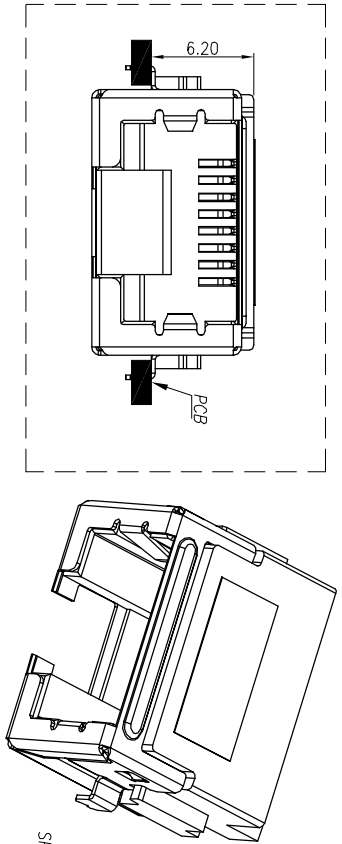
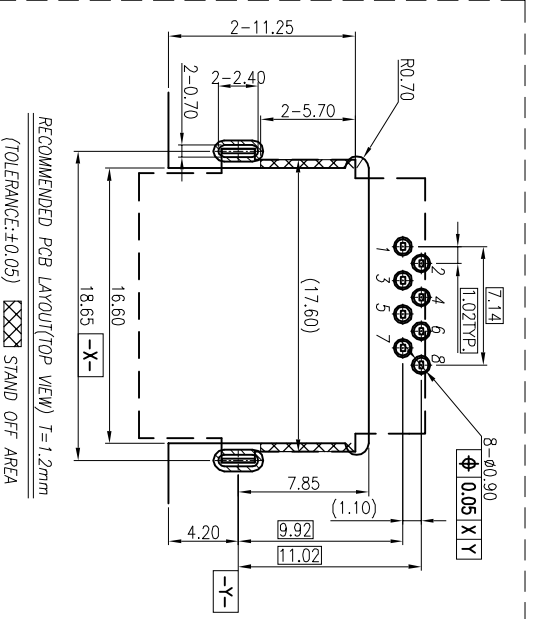
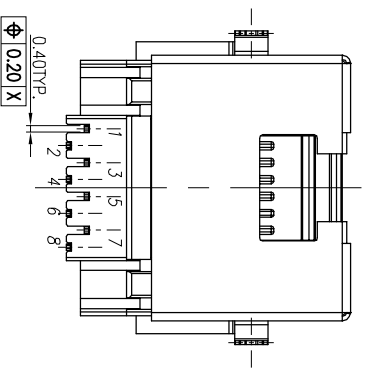

RECOMMENDED PCB LAYOUT(TOP VIEW) T=1.2mm
(TOLERANCE:±0.05) XXXX STAND OFF AREA

SPECIFICATIONS:

- ELECTRICAL CHARACTERISTICS:
 - CURRENT RATING: 1.5A MAX
 - VOLTAGE RATING: 150V MAX
 - CONTACT RESISTANCE: 50mΩ MAX(INITIAL), 100mΩ MAX(AFTER LIFE TEST), 100mΩ MIN.
 - INSULATION RESISTANCE: 100MΩ MIN.
- MECHANICAL CHARACTERISTICS:
 - DURABILITY: 5000 CYCLES.
 - INSERTION FORCE: 2.25kg MAX. WITH LATCH DEPRESSED.
 - WITHDRAWAL FORCE: 4.5kg MAX. WITH LATCH DEPRESSED.
 - OPERATING TEMPERATURE: -30°C ~ +70°C.
- PACKAGING : TAPE & REEL.
- TO CONFORM TO SINGATRON HAZARDOUS SUBSTANCE FREE SPEC.
- HALOGEN FREE PRODUCT IDENTIFICATION
- HALOGEN FREE PRODUCT IDENTIFICATION LOGO
- FOR REFLOW SOLDERING LEAD-FREE PROCESS.
- PRINTED DATE CODE "yy mm dd" ON THE CONNECTOR.

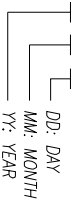

D	MYLAR	1	KAPTON FILM	W10*1.5
C	SHIELDING	1	STAINLESS STEEL TO.25	NL 40U" PLATING-ALL OVER
B	BP8C CONTACT	8	PHOSPHOR BRONZE T=0.25	G/F ON CONTACT AREA- Motte Sn 80u" ON SOLDER TAIL- ALL OVER IN 40U" MIN.
A	BODY	1	LCP E130+30%GF	UL 94V-0 & YELLOW(114)
NO	DESCRIPTION	QTY	MATERIAL	PLATING & COLOR

UNLESS OTHERWISE SPECIFIED TOLERANCES
 Singatron Enterprise Co., Ltd.
 信登企業股份有限公司

DECIMALS:	ANGLES:	TITLE
X : ±0.5	X : ±2°	RJ45 JACK 6.2H ON PCB
X.X : ±0.3	X.X : ±1°	DWN PAN PART NO:2R304B-028271F
X.XX : ±0.2		CHKD JAMES SCALE:4:1 UNIT: mm
		APVD BOYE SIZE: A3 SHEET:1 OF 1 REV:4

CUSTOMER COPY