

REV.	ECN NO. OR DESCRIPTION	REVISED	DATE
A	PDR NO.: I200113-1A	BING	2020.06.03

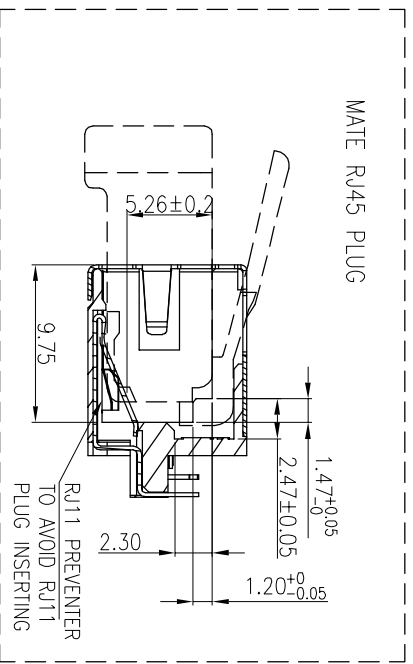

SPECIFICATIONS:

- ELECTRICAL CHARACTERISTICS:**
 - CURRENT RATING: 1.5A MAX.
 - VOLTAGE RATING: 150V MAX.
 - CONTACT RESISTANCE: 50mΩ MAX.(INITIAL), 100mΩ MAX.(AFTER LIFE TEST).
 - INSULATION RESISTANCE: 100MΩ MIN.
- MECHANICAL CHARACTERISTICS:**
 - DURABILITY: 5000 CYCLES.
 - INSERTION FORCE: 2.1kg MAX. WITH LATCH DEPRESSED.
 - WITHDRAWAL FORCE: 3kg MAX. WITH LATCH DEPRESSED.
 - OPERATING TEMPERATURE: -30°C ~ +80°C.
- MARKING: MARK "S" INSIDE OF THE CONNECTOR.
- PACKAGING: TAPE & REEL.
- TO CONFORM TO SINGATRON HAZARDOUS SUBSTANCE FREE SPEC.
- HALOGEN FREE PRODUCT IDENTIFICATION
- MARK ON PRODUCT:
- HALOGEN FREE PRODUCT IDENTIFICATION LOGO ON THE PACKAGING:
- FOR REFLOW SOLDERING LEAD-FREE PROCESS.
- PRINTED DATE CODE "YY MM DD" ON TOP OF THE CONNECTOR.

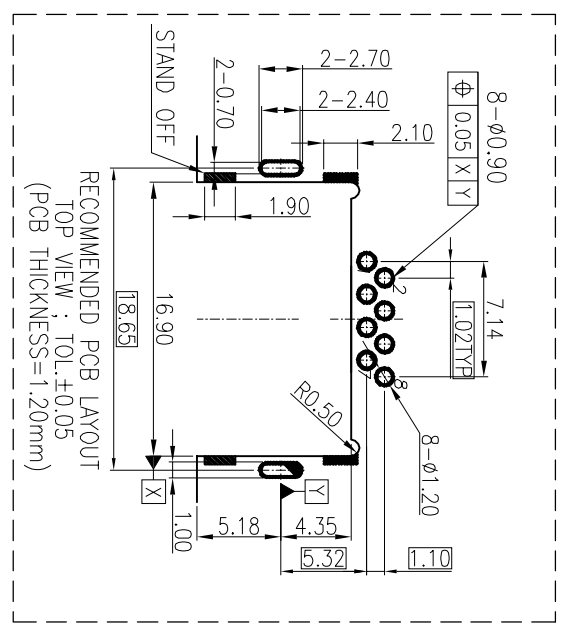
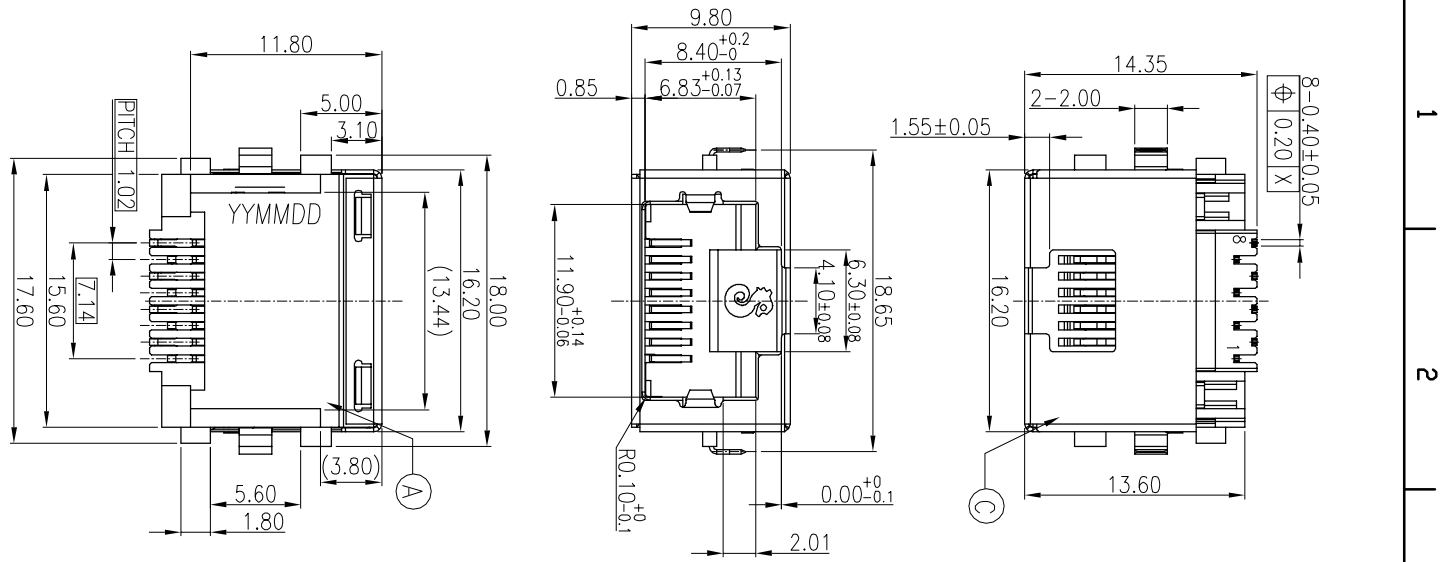
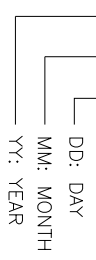

D	STOP	2	LCP	UL 94V-0 & BLACK
C	SHELL	1	STEEL T=0.25	NI 60μIN NIN可鍍
B	8P8C CONTACT	8	PHOSPHOR BRONZE T=0.25	Au 5μ" MIN ON CONTACT AREA; Matte Sn 120μ" ON SOLDER TAIL ALL OVER IN 50μ" MIN.
A	BODY	1	PA10T+30%GF	UL 94V-0 & BLACK
NO DESCRIPTION		QTY	MATERIAL	
UNLESS OTHERWISE SPECIFIED TOLERANCES		PLATING & COLOR		
Singatron Enterprise Co., Ltd. 信置企業股份有限公司				
DECIMALS:		ANGLES:	TITLE	
X	±0.5	X	±2°	RJ45 JACK
X.X	±0.3	X.X	±1°	PART NO. 2RJ3054-0E8211F
X.XX	±0.2			SCALE 4:1 UNIT: mm
				SHEET: 1 OF 1 REV: A
				CUSTOMER COPY