

REV.	ECN NO OR DESCRIPTION	REVISED	DATE
A	PDR NO:T130703-3A	JAMES	2014.01.13
B	ECN NO.S141108	JAMES	2014.11.03

SPECIFICATIONS:

- ELECTRICAL CHARACTERISTICS:
 - CURRENT RATING: 0.5A MAX.
 - VOLTAGE RATING: 150V MAX.
 - CONTACT RESISTANCE : 50mΩ MAX.(INITIAL).
100mΩ MAX.(AFTER LIFE TEST).
 - INSULATION RESISTANCE : 100MΩ MIN.
- MECHANICAL CHARACTERISTICS:
 - DURABILITY: 5000 CYCLES.
 - INSERTION FORCE: 2.25Kg MAX. WITH LATCH DEPRESSED.
 - WITHDRAWAL FORCE: 4.5Kg MAX. WITH LATCH DEPRESSED.
 - OPERATING TEMPERATURE: -30℃ ~ +70℃.
- MARKING: MARK "S" INSIDE OF THE CONNECTOR.
- PACKAGING : TAPE & REEL.
- TO CONFORM TO SINGATRON HAZARDOUS SUBSTANCE FREE SPEC.
- HALOGEN FREE PRODUCT IDENTIFICATION
MARK ON PRODUCT:
- HALOGEN FREE PRODUCT IDENTIFICATION LOGO
ON THE PACKAGING:
- FOR REFLOW SOLDERING LEAD-FREE PROCESS.
- PRINTED DATE CODE "YY MM DD" ON TOP OF THE CONNECTOR.

DD: DAY
MM: MONTH
YY: YEAR

NODE	COLOR	
A1(+)	A2(-)	Amber
B1(+)	B2(-)	White

E	LED	1	White
D	LED	1	Amber
C	SHELL	1	SUS301-1/2H 0.25T NI PLATING ALL OVER
B	8P8C CONTACT	8	C5210-EH 0.25T GOLD 1~3u" ON CONTACT AREA; Matte Sn 120u" ON SOLDER TAIL; ALL OVER Ni 50u"MIN.
A	BODY	1	LCP E130i UL 94V-0 & BLACK
NO	DESCRIPTION	QTY	MATERIAL
			PLATING & COLOR

UNLESS OTHERWISE SPECIFIED TOLERANCES		Singatron Enterprise Co., Ltd. 信音企業股份有限公司	
DECIMALS:	ANGLES:	TITLE	RJ45 JACK
X : ±0.50	X : ±2°	DWN	JAMES
X.X : ±0.30	X.X : ±1°	CHKD	
X.XX : ±0.20		APVD	BOYE
		PART NO.	2RJ3060-118211F
		SCALE	4:1
		UNIT	mm
		SHEET	1 / 2
		REV.	B
CUSTOMER COPY			

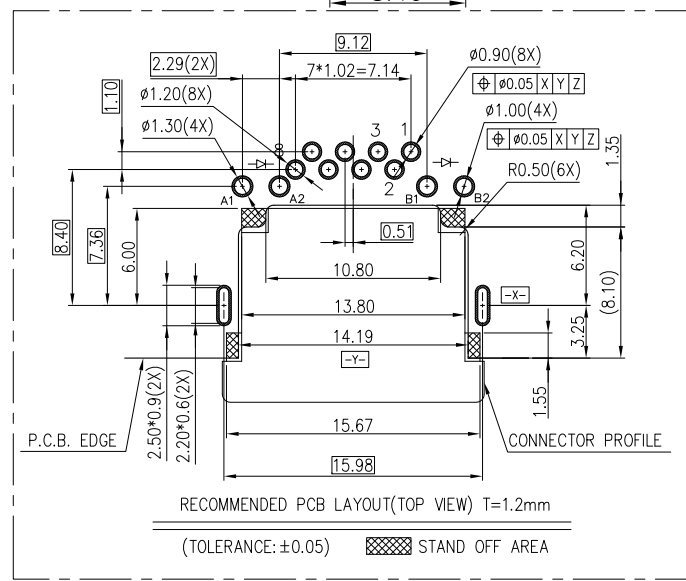
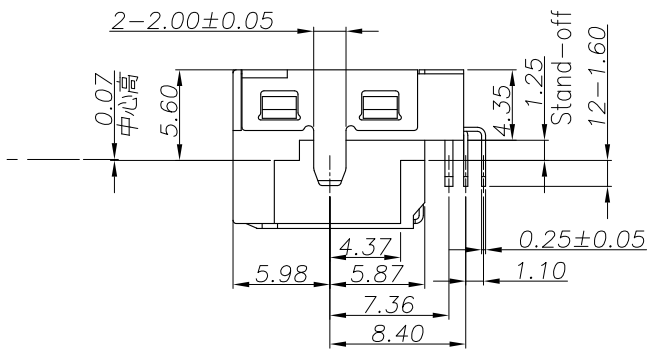
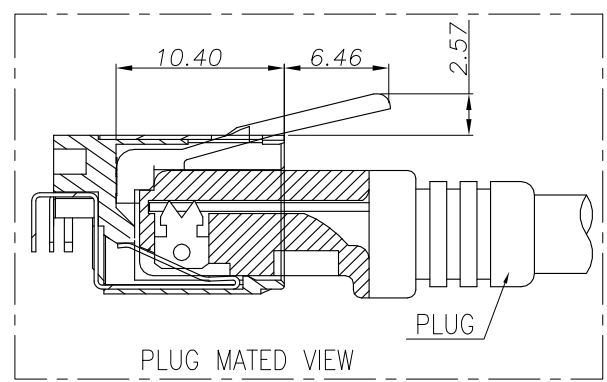

RECOMMENDED PCB LAYOUT (TOP VIEW) T=1.2mm
(TOLERANCE: ±0.05) STAND OFF AREA

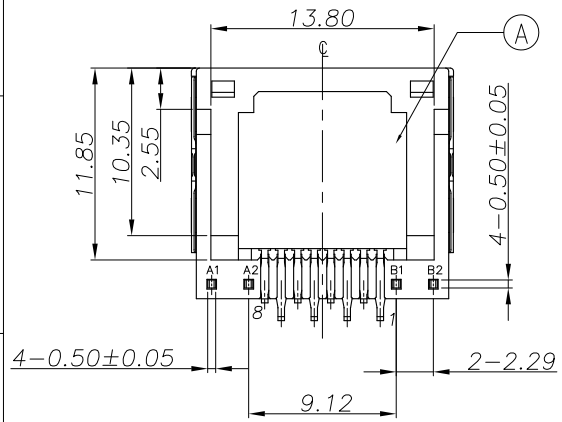
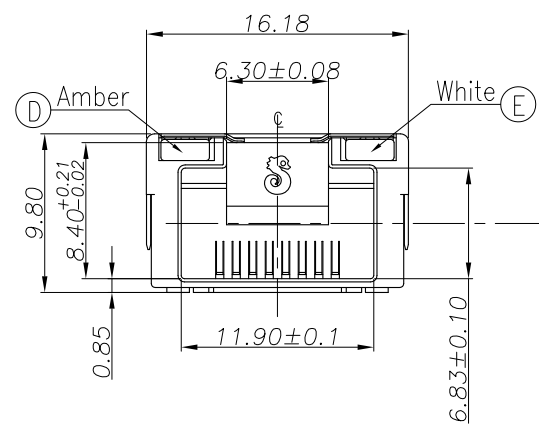
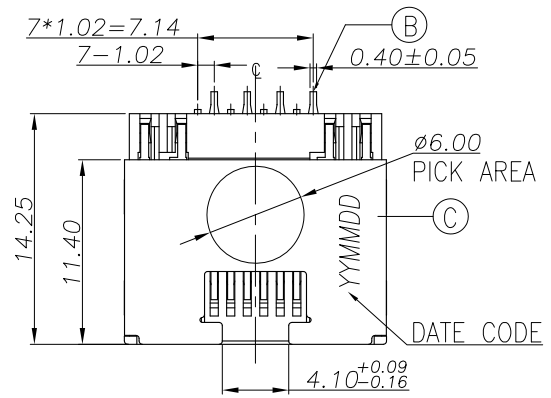

1 2 3 4 5 6 7 8

REV.	ECN NO OR DESCRIPTION	REVISED	DATE
A	PDR NO:T130703-3A	JAMES	2014.01.13
B	ECN NO.S141108	JAMES	2014.11.03

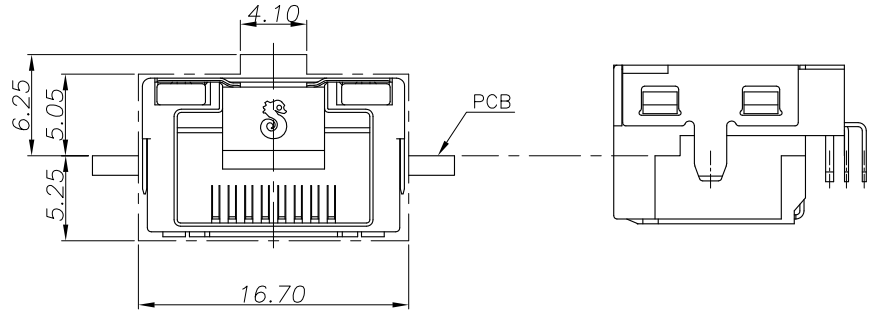

E	LED	1		White
D	LED	1		Amber
C	SHELL	1	SUS301-1/2H 0.25T	NI PLATING ALL OVER
B	8P8C CONTACT	8	C5210-EH 0.25T	GOLD 1~3u" ON CONTACT AREA; Matte Sn 120u" ON SOLDER TAIL; ALL OVER Ni 50u"MIN.
A	BODY	1	LCP E130i	UL 94V-0 & BLACK
NO	DESCRIPTION	QTY	MATERIAL	PLATING & COLOR

UNLESS OTHERWISE SPECIFIED TOLERANCES		 Singatron Enterprise Co., Ltd. 信音企業股份有限公司		
DECIMALS:	ANGLES:	TITLE	RJ45 JACK	
X ±0.50	X ±2°	DWN JAMES	PART NO.2RJ3060-118211F	
X.X ±0.30	X.X ±1°	CHKD	SCALE 4:1	UNIT: mm
X.XX ±0.20		APVD BOYE	SIZE: A3	SHEET: 2/2
CUSTOMER COPY				

1 2 3 4 5 6 7 8