

RECOMMENDED PCB LAYOUT
TOP VIEW ; TOL.±0.05
(PCB THICKNESS=1.20mm)

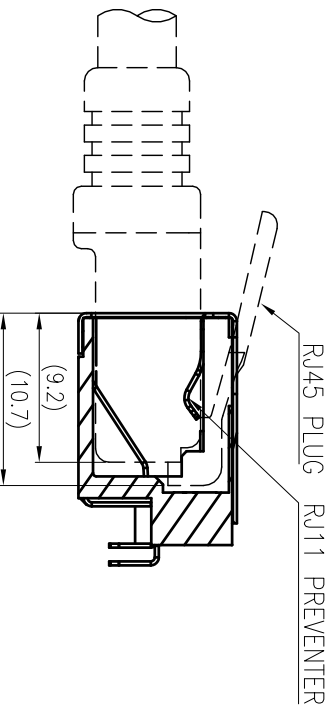

SPECIFICATIONS:

- ELECTRICAL CHARACTERISTICS:
 - CURRENT RATING: 0.5A MAX.
 - VOLTAGE RATING: 150V MAX.
 - CONTACT RESISTANCE : 50mΩ MAX.(INITIAL), 100mΩ MAX.(AFTER LIFE TEST).
 - INSULATION RESISTANCE : 100MΩ MIN.
- MECHANICAL CHARACTERISTICS:
 - DURABILITY: 5000 CYCLES.
 - INSERTION FORCE: 2.25kg MAX. WITH LATCH DEPRESSED.
 - WITHDRAWAL FORCE: 4.5kg MAX. WITH LATCH DEPRESSED.
 - OPERATING TEMPERATURE:-30°C ~ +70°C.
- MARKING: MARK "S" INSIDE OF THE CONNECTOR.
- PACKAGING : TAPE & REEL.
- TO CONFORM TO SINGATRON HAZARDOUS SUBSTANCE FREE SPEC.
- HALOGEN FREE PRODUCT IDENTIFICATION
- MARK ON PRODUCT: ○
- HALOGEN FREE PRODUCT IDENTIFICATION LOGO ON THE PACKAGING: ●
- FOR REFLOW SOLDERING LEAD-FREE PROCESS.
- PRINTED DATE CODE "XY MM DD " ON TOP OF THE CONNECTOR.

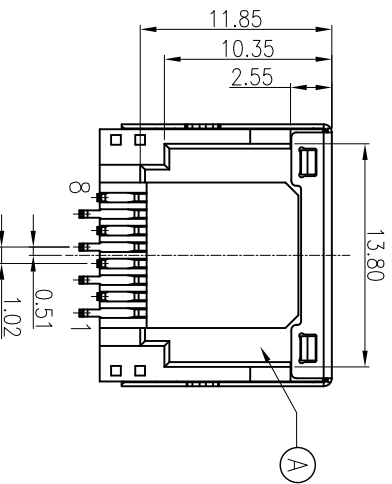
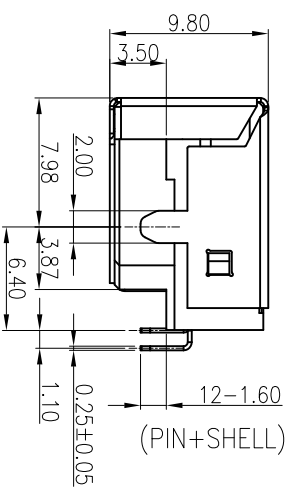
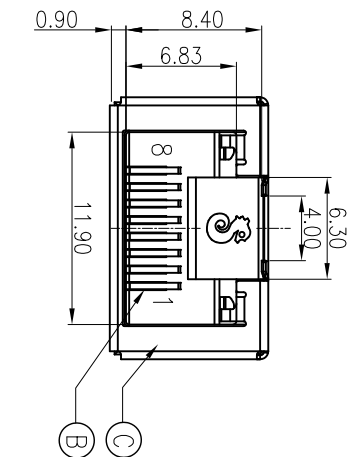

C	SHELL	1	STAINLESS STEEL T:0.25mm	NI PLATING ALL OVER
B	8P8C CONTACT	8	PHOSPHOR BRONZE T:0.25mm	G/F ON CONTACT AREA: Matte Sn 120u" ON SOLDER TAIL; ALL OVER Ni 50u"MIN.
A	BODY	1	HIGH TEMP.THERMOPLASTIC	UL 94V-0 & BLACK
NO	DESCRIPTION	QTY	MATERIAL	PLATING & COLOR
UNLESS OTHERWISE SPECIFIED TOLERANCES				
DECIMALS:	ANGLES:			
X :±0.5	X :±2°			
X.X :±0.3	X.X :±1°			
X.XX :±0.2				

Singatron Enterprise Co., Ltd.
信營企業股份有限公司

TITLE	RJ45 JACK		
DWM	Sam	PART NO.	2RJ3062-018211F
CHKD		SCALE	4:1
APVD	James	UNIT:	mm
		SIZE:	A3
		SHEET:	1 / 1
		REV:	A

CUSTOMER COPY