

SPECIFICATIONS:

- 1. ELECTRICAL CHARACTERISTICS:**
- 1-1. CURRENT RATING: 0.5A MAX.
 - 1-2. VOLTAGE RATING: 150V MAX.
 - 1-3. CONTACT RESISTANCE: 50mΩ MAX.(INITIAL), 100mΩ MAX.(AFTER LIFE TEST), 100mΩ MIN.
 - 1-4. INSULATION RESISTANCE: 100MΩ MIN.
- 2. MECHANICAL CHARACTERISTICS:**
- 2-1. DURABILITY: 5000 CYCLES.
 - 2-2. INSERTION FORCE: 2.25kg MAX. WITH LATCH DEPRESSED.
 - 2-3. WITHDRAWAL FORCE: 4.5kg MAX. WITH LATCH DEPRESSED.
 - 2-4. OPERATING TEMPERATURE: -30°C ~ +70°C.
- 3. MARKING: MARK "Ⓢ" INSIDE OF THE CONNECTOR.
 - 4. PACKAGING: TAPE & REEL.
 - 5. TO CONFORM TO SINGATRON HAZARDOUS SUBSTANCE FREE SPEC.
 - 6. HALOGEN FREE PRODUCT IDENTIFICATION
 - 7. HALOGEN FREE PRODUCT IDENTIFICATION LOGO ON THE PACKAGING:
 - 8. FOR REFLOW SOLDERING LEAD-FREE PROCESS.
 - 9. PRINTED DATE CODE "YY MM DD" ON TOP OF THE CONNECTOR.



REV.	ECN NO. OR DESCRIPTION	REVISED	DATE
B	ECN NO:S130730	JAMES	2013.09.22
C	ECN NO:S141045	Allen	2014.12.01
D	ECN NO:S160621-R	Allen	2016.06.13

NODE	COLOR	
AZ(+)	A1(-)	YELLOW
BZ(+)	B1(-)	GREEN
E		GREEN
D		YELLOW
C		STAINLESS STEEL T:0.25mm
B		PHOSPHOR BRONZE T:0.25mm
A		HIGH TEMP.THERMOPLASTIC

NO	DESCRIPTION	QTY	MATERIAL	PLATING & COLOR
C	SHELL	1	STAINLESS STEEL T:0.25mm	NI PLATING ALL OVER
B	SPRC CONTACT	8	PHOSPHOR BRONZE T:0.25mm	G/F ON CONTACT AREA, Matte Sn 120u" ON SOLDER TAIL, ALL OVER NI:50u"MIN
A	BODY	1	HIGH TEMP.THERMOPLASTIC	UL 94V-0 & BLACK

UNLESS OTHERWISE SPECIFIED TOLERANCES	ANGLES
DECIMALS: X :±0.5	X :±2°
XX :±0.3	XX :±1°
XXX :±0.2	

TITLE	PART NO.	SCALE	UNIT	SHEET	REV.
RJ45 JACK	2RJ3062-108211F	4:1	mm	1 / 2	D

Singatron Enterprise Co., Ltd.
 信登企業股份有限公司
 CUSTOMER COPY

REV.	ECN NO. OR DESCRIPTION	REVISED	DATE
B	ECN NO:S130730	JAMES	2013.09.22
C	ECN NO:S141045	Allen	2014.12.01
D	ECN NO:S160621-R	Allen	2016.06.13

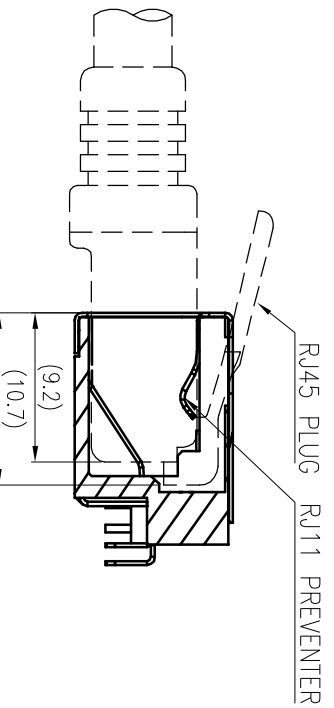

MATE RJ45 PLUG
REFERENCE

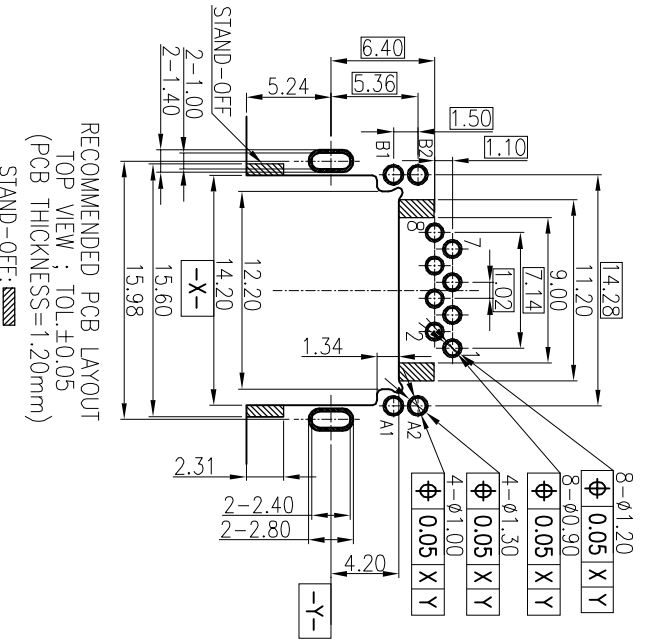

RECOMMENDED PCB LAYOUT
TOP VIEW : TOL.±0.05
(PCB THICKNESS=1.20mm)
STAND-OFF:

NO	DESCRIPTION	QTY	MATERIAL	PLATING & COLOR
E	LED	1	GREEN	
D	LED	1	YELLOW	
C	SHELL	1	STAINLESS STEEL T:0.25mm	NI PLATING ALL OVER
B	8P8C CONTACT	8	PHOSPHOR BRONZE T:0.25mm	C/F ON CONTACT AREA: Motte Sn 120u" ON SOLDER TAIL: ALL OVER Ni 50u"MIN.
A	BODY	1	HIGH TEMP.THERMOPLASTIC	UL 94V-0 & BLACK

UNLESS OTHERWISE SPECIFIED TOLERANCES
DECIMALS: ANGLES:
X :±0.5 X :±2°
X.X :±0.3 X.X :±1°
X.XX :±0.2

Singatron Enterprise Co., Ltd.
信晉企業股份有限公司

TITLE	RJ45 JACK			
DWN	Allen	PART NO.	2RJ3062-108211F	
CHKD	JAMES	SCALE	4:1	UNIT: mm
APVD	Boye	SIZE:	A3	SHEET:2 / 2 REV: D

CUSTOMER COPY

