

REV.	ECN NO. OR DESCRIPTION	REVISED	DATE
A	PDR NO:170824-3A	ALLEN	2018.01.05
B	ECN NO:5202008-C18	YangXiao	2020.09.08

**SPECIFICATIONS:**

- ELECTRICAL CHARACTERISTICS:
  - CURRENT RATING: 1.5A MAX.
  - VOLTAGE RATING: 150V MAX.
  - CONTACT RESISTANCE: 50mΩ MAX.(INITIAL), 100mΩ MAX.(AFTER LIFE TEST).
  - INSULATION RESISTANCE: 100MΩ MIN.
- MECHANICAL CHARACTERISTICS:
  - DURABILITY: 5000 CYCLES.
  - INSERTION FORCE: 2.25kg MAX. WITH LATCH DEPRESSED.
  - WITHDRAWAL FORCE: 4.5kg MAX. WITH LATCH DEPRESSED.
  - OPERATING TEMPERATURE: -30℃ ~ +70℃.
- MARKING: MARK "S" INSIDE OF THE CONNECTOR.
- PACKAGING: TAPE & REEL.
- TO CONFORM TO SINGATRON HAZARDOUS SUBSTANCE FREE SPEC.
- HALOGEN FREE PRODUCT IDENTIFICATION
- HALOGEN FREE PRODUCT IDENTIFICATION LOGO ON THE PACKAGING: 
- FOR REFLOW SOLDERING LEAD-FREE PROCESS.
- PRINTED DATE CODE "YY MM DD" ON TOP OF THE CONNECTOR.

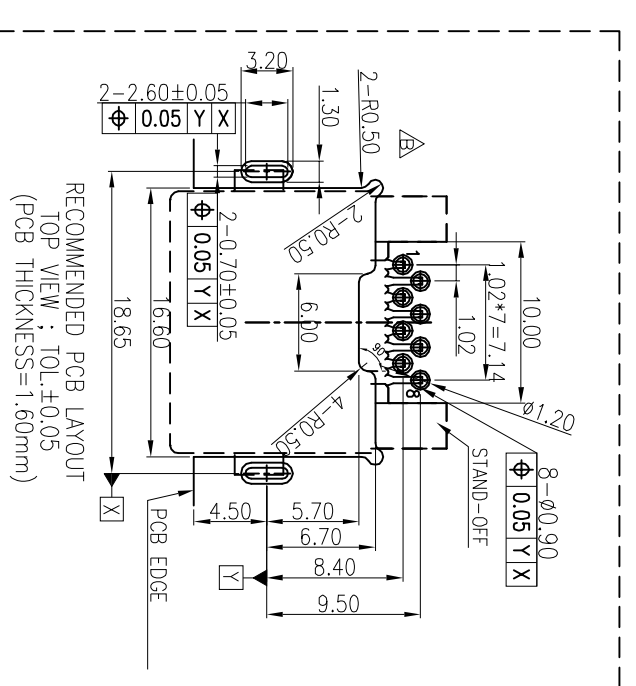
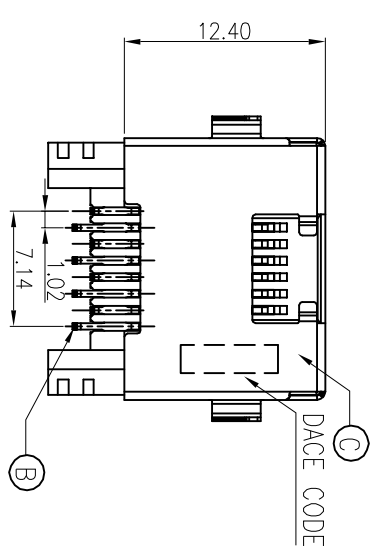
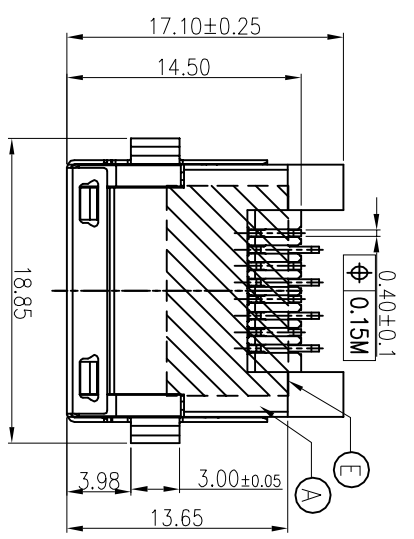
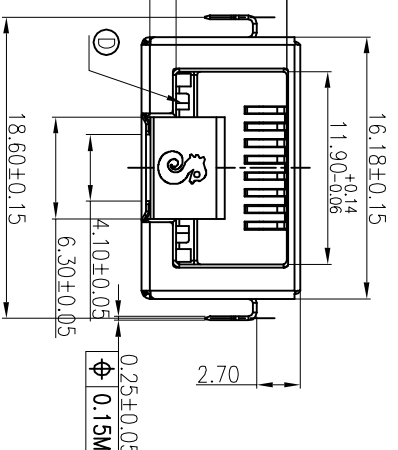
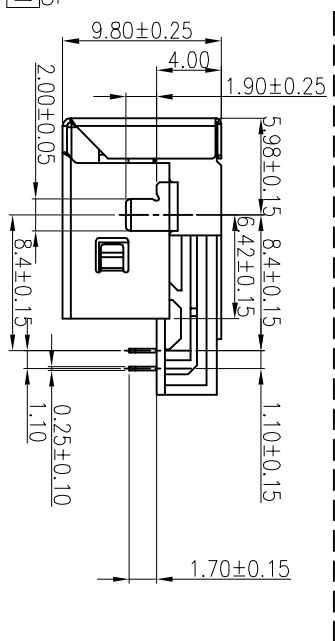
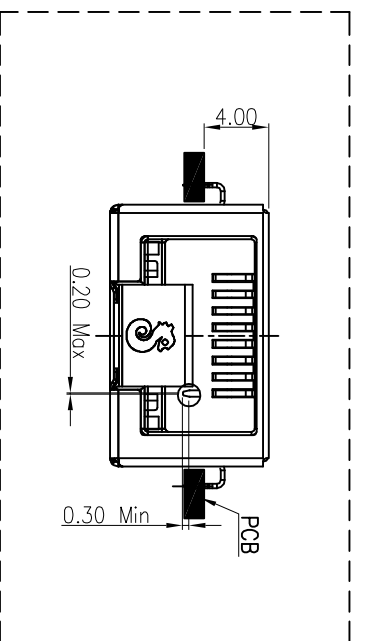

NO	DESCRIPTION	QTY	MATERIAL	PLATING & COLOR
E	Mylar	1	T=0.06	BLACK
D	STOP	2	SUS304 1/2H	
C	SHELL	1	STAINLESS STEEL	NI PLATING ALL OVER
B	8P8C CONTACT	8	PHOSPHOR BRONZE	Au:5u" ON CONTACT AREA; Mo:1e Sn 120u" ON SOLDER TAIL; ALL OVER NI 50u"MIN.
A	BODY	1	LCP	UL 94V-0 & BLACK

Singatron Enterprise Co., Ltd  
信亨企業股份有限公司

DECIMALS:	ANGLES:
X : ±0.5	X : ±2°
X.X : ±0.3	X.X : ±1°
X.XX : ±0.2	

TITLE	R/45 JACK
DWN	YangXiao
CHKD	James
APVD	Boye

PART NO. 2RJ3070-058211F  
SCALE 4:1  
UNIT: mm  
SHEET: 1 / 1  
REV: B  
CUSTOMER COPY