

RECOMMENDED PCB LAYOUT
TOP VIEW : TOL.±0.05
(PCB THICKNESS=1.00mm)

SPECIFICATIONS:

- ELECTRICAL CHARACTERISTICS:
 - CURRENT RATING: 1.5A MAX.
 - VOLTAGE RATING: 150V MAX.
 - CONTACT RESISTANCE : 50mΩ MAX.(INITIAL), 100mΩ MAX.(AFTER LIFE TEST).
 - INSULATION RESISTANCE : 100MΩ MIN.
 - Dielectric Withstanding Voltage : 500 V AC Max.
- MECHANICAL CHARACTERISTICS:
 - DURABILITY: 5000 CYCLES.
 - INSERTION FORCE: 2.25Kg MAX. WITH LATCH DEPRESSED.
 - WITHDRAWAL FORCE: 4.5Kg MAX. WITH LATCH DEPRESSED.
 - OPERATING TEMPERATURE: -30℃ ~ +70℃.
- MARKING: MARK "S" INSIDE OF THE CONNECTOR.
- PACKAGING : TAPE & REEL.
- TO CONFORM TO SINGATRON HAZARDOUS SUBSTANCE FREE SPEC.
- HALOGEN FREE PRODUCT IDENTIFICATION MARK ON PRODUCT: ♻️
- HALOGEN FREE PRODUCT IDENTIFICATION LOGO ON THE PACKAGING: ♻️
- FOR REFLOW SOLDERING LEAD-FREE PROCESS.
- PRINTED DATE CODE "YY MM DD" ON TOP OF THE CONNECTOR.



NODE	COLOR	Wavelength
A2(+)	AMBER	A2-→A1
B2(+)	WHITE	B2-→B1

G	MYLAR	1	MYLAR O.06t	TRANSPARENT
F	R111 STOPPER	2	HIGH TEMP.THERMOPLASTIC	UL 94V-0 & BLACK
E	LED	1		AMBER
D	LED	1		WHITE
C	SHELL	1	STAINLESS STEEL T:0.25mm	NI PLATING ALL OVER
B	TERMINAL	8	PHOSPHOR BRONZE	NI PLATING ALL OVER C/F ON CONTACT AREA: Mette Sn 120u" ON SOLDER TAIL: ALL OVER IN 50u"MIN.
A	HOUSING	1	HIGH TEMP.THERMOPLASTIC	UL 94V-0 & BLACK
NO	DESCRIPTION	QTY	MATERIAL	PLATING & COLOR

UNLESS OTHERWISE SPECIFIED TOLERANCES

Singatron Enterprise Co., Ltd.
信晉企業股份有限公司

TITLE	DECIMALS:	ANGLES:
DWN	±0.5	X ±12°
CHKD	±0.3	X.X ±1°
APVD	±0.2	X.XX ±0.2

CUSTOMER COPY

REV.	ECN NO OR DESCRIPTION	REVISED	DATE
A	PDR NO: T141117-5A	ALLEN	2015.03.23
B	ECN NO: S181237-R	PAN	2019.07.12

公母對插示意圖

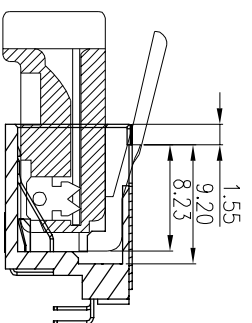

Before IR Reflow Dimensions Spec

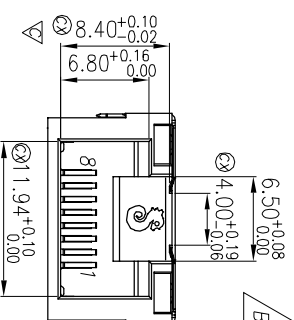

After IR Reflow Dimensions Spec

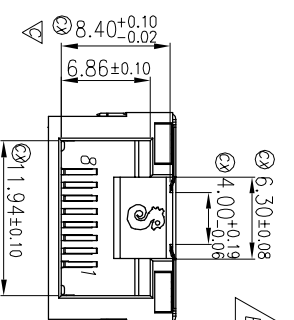

防R11示意圖

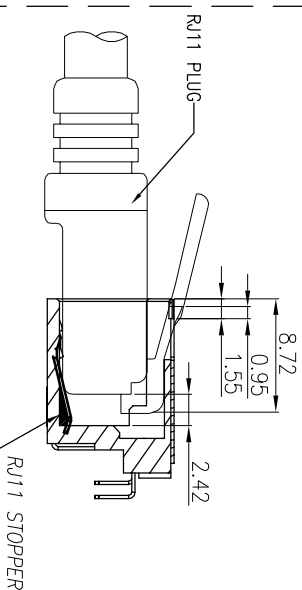

Contact Check
worse case

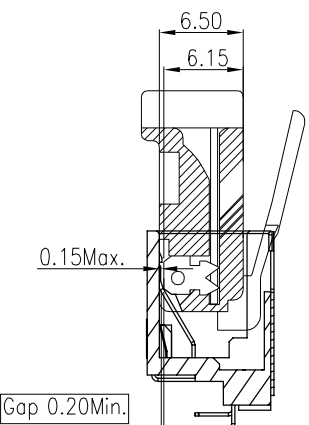

Contact Check
worse case

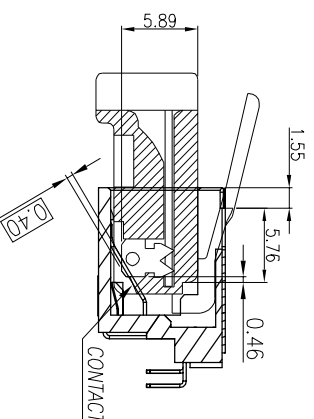

NO	DESCRIPTION	QTY	MATERIAL	PLATING & COLOR
UNLESS OTHERWISE SPECIFIED TOLERANCES				
Singatron Enterprise Co., Ltd. 信晉企業股份有限公司				
TITLE: R445 JACK				
DECIMALS:		ANGLES:		
X	:±0.5	X	:±2°	
X.X	:±0.3	X.X	:±1°	
X.XX	:±0.2			

TITLE	PART NO.	UNIT	REV.
ALLEN	2RJ3075-138211F	mm	
JAMES	SCALE 4:1		
BOYE	SIZE: A3	SHEET: 2 OF 2	REV: B

CUSTOMER COPY